

ALARM CONTROLS For Model 105/106/109 Gauges

Mid-West Instrument's "Locked Logic" solid state optical alarm controls feature friction free optical sensing for precise alarm set points without affecting the gauges indicating accuracy.

The "Locked Logic" system is all solid state and is available with one or two set pointers and weatherproof or explosion-proof housings.

Alternate configurations such as adjustable deadband, bi-directional dial, and DPDT outputs are also available.

Additional features include:

- Large Dial - 12"(300mm) Scale Length
- One or two visible set pointers
- Optional Power Inputs
 - 8-28 VDC
 - 110-170 VDC
 - 120 VAC
 - 240 VAC
- Standard Electrical Output (Resistive Load)
 - 10 AMP @ 30 VDC
 - 10 AMP @ 115/230 VAC-50/60 Hz
- Optional wide adjustable Deadband (From 5 to 95% of Full Scale)



**Weatherproof
enclosure**

**Explosion-proof
enclosure**



Accuracy plus Reliability

The Mid-West “Locked Logic” control system utilizes miniaturized solid state components that have proved their reliability and ruggedness in a variety of industrial process applications. These components have been combined in a new generation of indicating controls.

This concept provides units that are competitively priced and give superior performance as the result of a design that offers —

- **Freedom from friction — no contacts, no springs, no sliding wearing wipers**
- **Freedom from moving parts — all solid state, no wear, no shift, no misalignment**

- **Freedom from mechanical contacts — no burn-out, no erosion, no chatter, no erratic signals**
- **Freedom from auxiliary encumbrances — no vanes, no levers, no cams**
- **Freedom from error — no friction, reaction nor interaction with gauge measurement**
- **Explosion-proof option available: — Division I, Class I, Groups B, C, & D; Class II Groups E, F & G**

Design & Operation

The “Locked Logic” design utilizes two reflective optical sensors per set pointer to detect a mirrored target on the gauge indicating pointer as it passes a desired set point. Two sensors per set pointer provide hysteresis for oscillation prevention. The sensors are positioned so that upon increasing differential pressure, the right sensor determines the “Upper Trigger Point” (U.T.P.) and upon decreasing differential pressure (assuming Δp above U.T.P.), the left sensor determines the “Lower Trigger Point” (L.T.P.). The algebraic difference between the U.T.P. and L.T.P. determines the set pointer hysteresis (fixed nominally at 2%).

Figure 1 illustrates the two sensors on the control set pointer, the mirrored target on the indicating pointer, and the logic sequence, as the gauge indicating pointer moves across the control set point. For this example, “on” is defined as the output relay energized and “off” as the output relay de-energized.

With the gauge pointer below the set point S, (i.e. position A) the output is “off”. The output

will remain “off” until differential pressure increases and the gauge pointer passes position “S”, which is determined by the U.T.P. sensor. As the gauge pointer moves further upscale (i.e. position D), the output will remain “on”. For the reverse direction, the output will remain “on” until the gauge pointer passes position “B”, which is determined by the L.T.P. sensor.

The “Locked Logic” design is also available with two set pointers configured for adjustable deadband functionality. For this option, the left set pointer determines the L.T.P. and the right set pointer determines the U.T.P. The deadband can be adjusted from 5 to 95% of the range span, with both set pointers controlling one S.P.D.T. or D.P.D.T. relay output. LED indications for this option are on the left set pointer only. Green shall indicate when the output is “off” and red shall indicate when the output is “on”. Applications for this option include; level control, differential pressure filter backwash, and by-pass flow control.

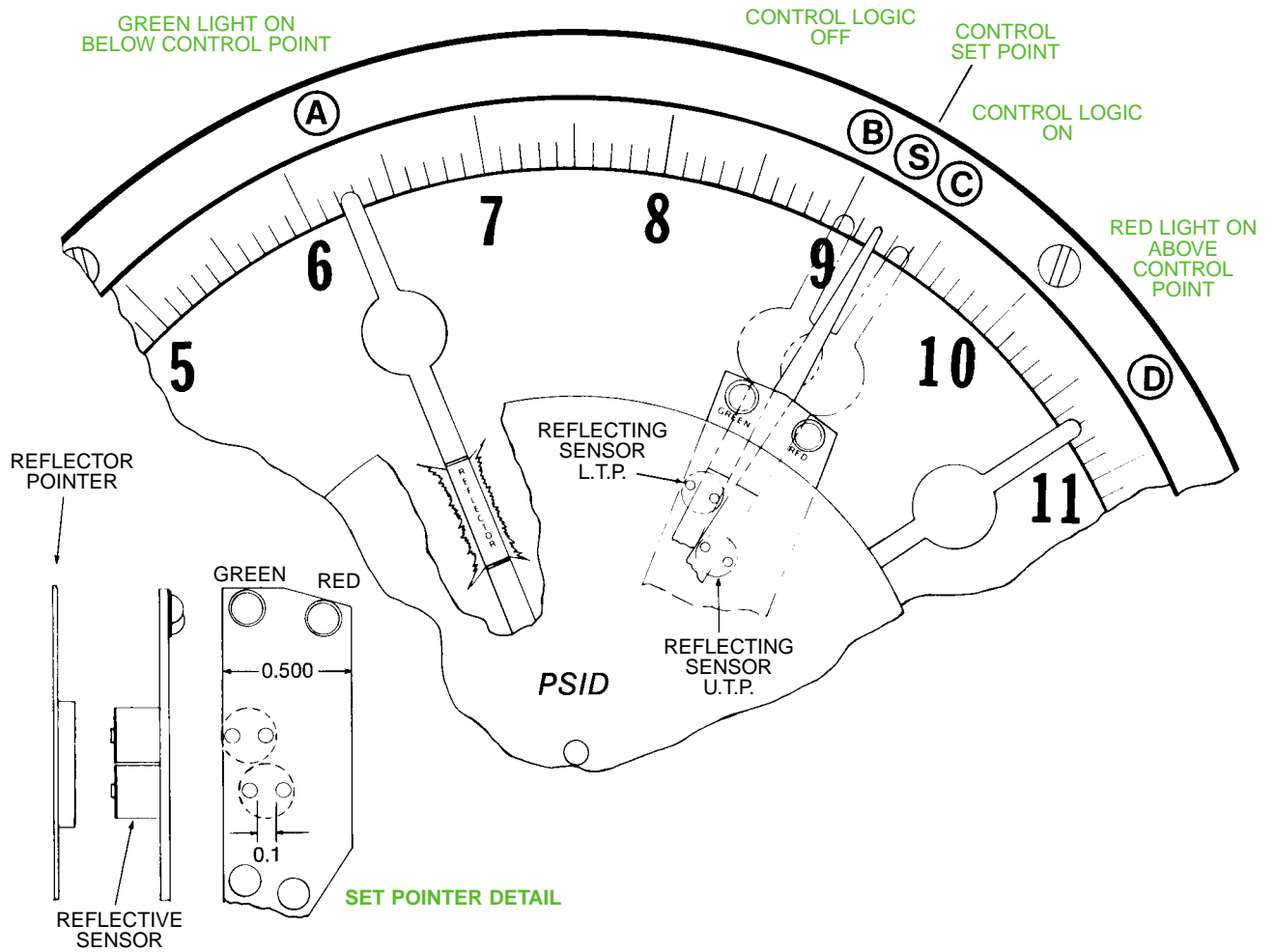
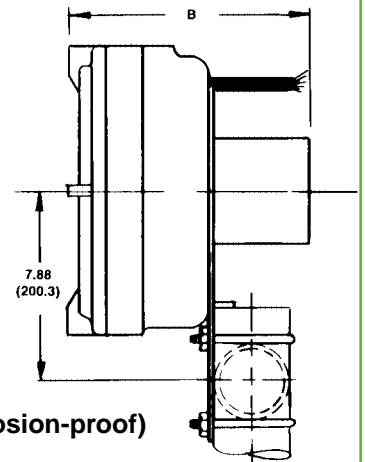
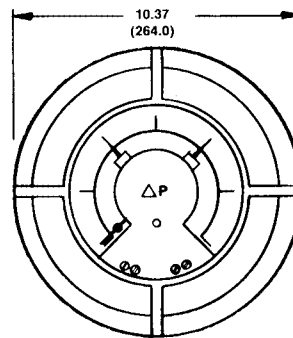
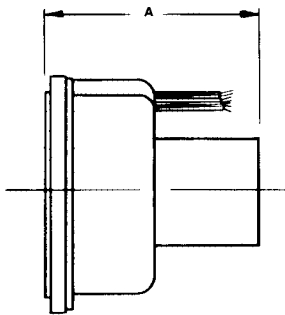
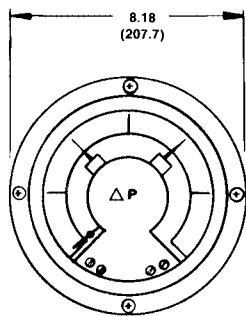

FIGURE 1 — Locked Logic control arrangement

MOUNTING INFORMATION & DIMENSIONAL DATA



(Weatherproof)

MODEL	A	B
105	7.73 (196.3)	8.86 (225.0)
106	7.25 (184.1)	8.38 (212.8)
109	6.50 (165.1)	7.63 (193.8)

(Explosion-proof)

Weight:

Weatherproof
Weatherproof (110-170 Vdc)
Explosion-proof

Aluminum

12 lbs.
17 lbs.
23 lbs.

Brass

19 lbs.
24 lbs.
30 lbs.

NOTES: 1. Drawings show standard gauge nominal dimensions. (not to scale)
2. Dimensions shown in parentheses are in millimeters.

SPECIFICATIONS

Input Voltage:	Standard Range:	8 to 28 VDC	Select one of four input ranges.	
	Optional:	110 to 170 VDC 85 to 165 VAC 153 to 345 VAC		
	Reverse Polarity:	8 to 28 VDC		Input Polarity Protected Not Applicable for AC units
	Power Loss:	< 2 seconds		Loss of input power less than 2 seconds unit will remember last state of output(s).
	Logic Reset:	> 4 seconds	To reset logic, power must be off for greater than 4 seconds before re-application of input power.	
Input Current:	DC Inputs:	400 ma. maximum	Steady State Values	
	AC Inputs:	100 ma. maximum		
Set Pointers:	Quantity:	1 or 2		
	Adjust:	5% to 95% of Full Scale		
	Set 1 to Set 2 Diff.:	5% of Full Scale (Nominal) 2 set point units only		
Output(s):	Contact(s):	1 or 2 SPDT or DPDT		
	Contact Rating:	10 Amps Maximum	@ ≤30 VDC	
		10 Amps Maximum	@ 115/240 VAC	
Temperature:	Operating:	-40°F to +160°F / -40°C to +70°C		
Environment:	Standard:	Weatherproof Housing	NEMA 4	
	Optional:	Explosion-proof Housing	Class I, Groups B, C & D Class II, Groups E, F, & G	
Electrical Interface:	Standard:	2Ft., 18 Awg., 600V, 105°C color coded wire leads	1/2" FNPT for 1 or 2 SPDT Outputs and 1 DPDT Output. 3/4" FNPT for 2 DPDT Outputs.	
	Optional	Flexible metal conduit Weatherproof flexible metal conduit Extra lengths of either of above		
	Drawings:	101384 107882 108047 108158 108479 108736	8-28 VDC Input, SPDT Output 120/240 VAC Input, SPDT Output AC Input, 1 DPDT Output AC Input, 2 DPDT Output DC Input, 1 DPDT Output DC Input, 2 DPDT Output	
Materials Construction:	Weatherproof:	Cast Aluminum with "engineering plastic" bezel		
	Explosion-proof:	Cast Aluminum		

Manufacturer reserves the right to change specifications without prior notice.

Mid-West[®]
Instrument

6500 Dobry Dr. □ Sterling Heights, MI 48314 U.S.A.
(586) 254-6500 □ FAX (586) 254-6509
E-mail: sales@midwestinstrument.com
Website: www.midwestinstrument.com



REPRESENTED BY: