

Model 130 Installation and Operating Instructions

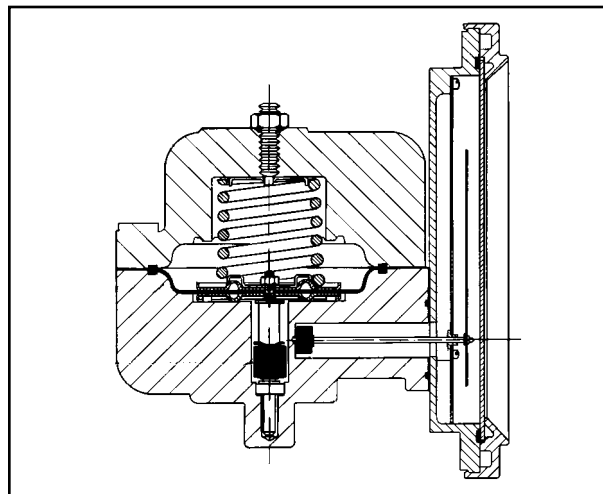

INSPECTION

Before installation check nameplate on each instrument against the receiving paperwork and the intended application for correct part number, materials, working pressure, dial range, etc. If equipped with switches, check electrical rating, type of enclosure, etc. Inspect for shipping damage. If damaged, report it immediately.

NOTE - Before attempting repairs contact your local Mid-West Representative or our factory. Failure to do so will void any warranty.

PRODUCT DESCRIPTION

The Model 130 is a differential pressure instrument available as a switch, gauge, or both. See "Part Numbering System", (Fig. 2).

A flexible elastomer diaphragm and calibrated range spring are moved by differential pressure. A

magnet, coupled with the diaphragm, transmits motion through the wall of the pressure housing to a follower magnet attached to an indicating pointer. The rotation of the follower magnet causes the pointer to track movement of internal magnet and indicate differential on the dial scale.

When equipped with switches for Aluminum, Brass or 316SS bodies only, a contact is made or broken by the magnetic field of the internal magnet.

The diaphragm is totally supported upon reaching full travel in either direction, providing full over-range protection to rated working pressure.

INSTALLATION

Model 130 is calibrated and tested prior to shipment and is ready for immediate installation. Use of the following installation procedures should eliminate potential damage and provide optimum trouble-free operation.

NOTE - It is highly recommended that a three valve manifold be installed in the instrumentation loop to minimize possible damage during pressurization.

1. CONNECTIONS

Model 130 P is provided with 1/4" compression tube fittings, one low and one high, on the top and bottom of gauge body.

Model 130 A, B, H, S, is provided with **dual** 1/4" FNPT connections top and bottom as standard. One pair of high and low pressure ports is for process connections. The other pair is plugged or used as drain/bleed connections.

Ports are identified for high and low pressure. Be sure to plumb to proper connections on system. Improper connection will not damage instrument but it will not function properly.

Flexible tubing is recommended to minimize effect of any vibration that may exist.

When attaching connections to the 130 P, care must be taken to prevent over-tightening which may result in stripping threads and/or cracking ports. In order to prevent this, use a suitable wrench to hold the factory supplied fitting in place while tightening, sometimes called "double wrenching".

2. INSTRUMENT LOCATION

On liquid service, the instrument should be mounted **below** the process connections to facilitate self-bleeding. On gas service, it should be located **above** the process connections to promote self-draining. If the process contains particulates, a "pigtail" loop or drop leg (manometer "U-tube" configuration) in the tubing will minimize the possibility of it migrating into the instrument.

NOTE - On liquid applications, unequal liquid heads on high or low side will result in an inaccurate differential pressure indication.

3. PANEL MOUNTING

The Model 130 is designed for mounting through the **front** of the instrument panel and is provided with a panel mount kit, consisting of (4) panel mounting studs/nuts.

Make cutouts as indicated in (Fig. 1). Insert (4) panel mounting studs, finger tight, into metal inserts located in the rear of the bezel.

Insert gauge through the panel, aligning panel mounting studs with holes in the panel. Install #8-32 nuts onto studs and tighten securely.

4. PIPE MOUNTING

If specified, your Model 130 will have a pipe mount kit installed. This provides for mounting on a 2" vertical or horizontal pipe. See (Fig. 1).

5. ELECTRICAL - See Mid-West Bulletin IMELEC130/latest

TROUBLE SHOOTING

1. Gauge does not indicate differential.

- A. Check for proper hook up, high to "hi" and low to "lo".
- B. Make certain block valves are open and, if using a 3-valve manifold, that the equalizer (balance) valve is closed.
- C. If A & B check out, loosen high pressure line to determine if there is pressure to instrument.
- D. If there is pressure to instrument, check to determine that there is differential across the unit being monitored. If so, contact factory for assistance and/or an "RGA" (return goods authorization) number to return instrument for repair or replacement.

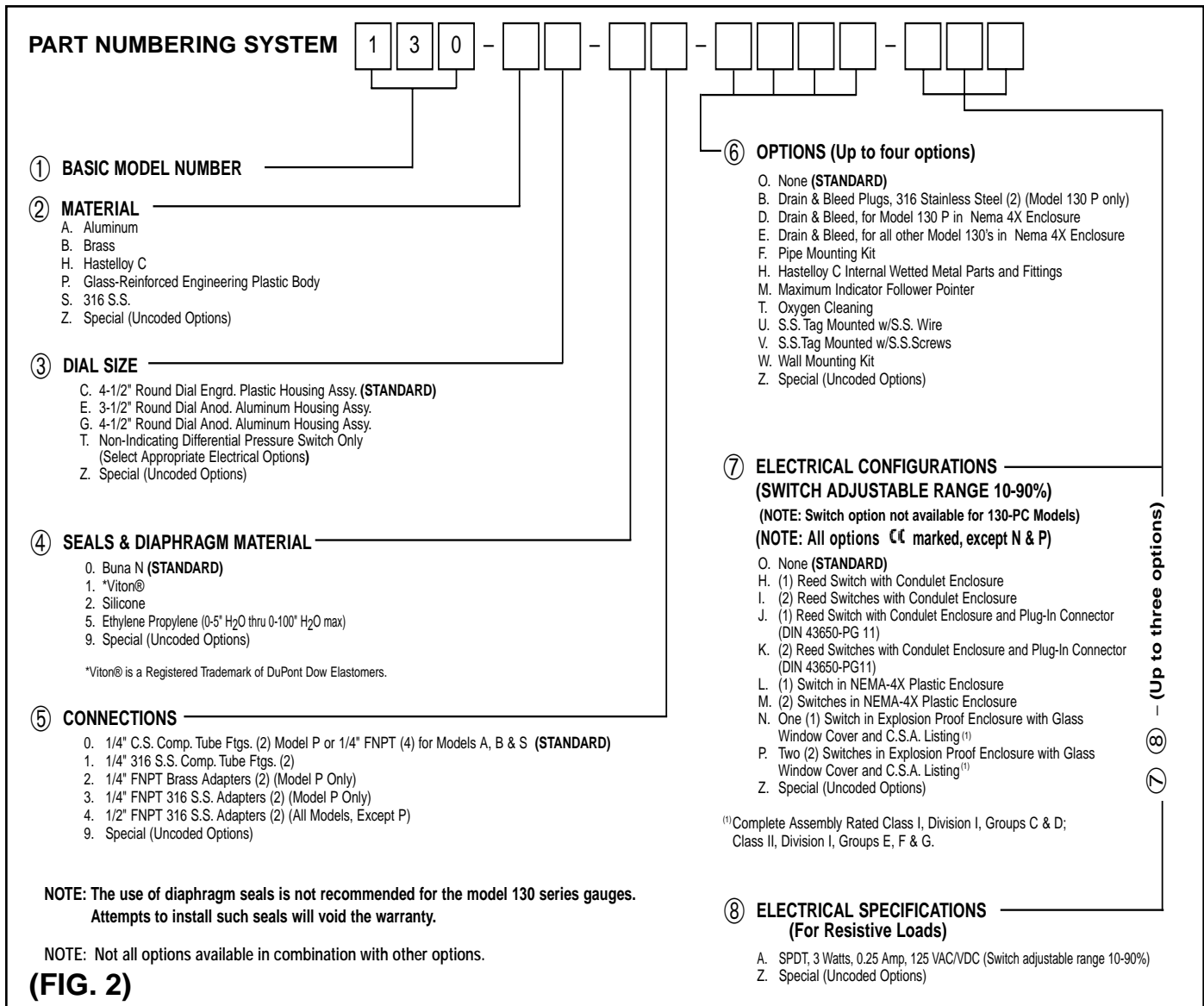

Manufacturer reserves the right to change specifications without prior notice.

Temperature limitations: -40°F(-40°C) to +200°F (+93°C). **Proof pressure:** two times rated working pressure.

NOTE: These limits are based on the entire instrument being saturated to these temperatures. Systems (process) temperatures may exceed these limitations with proper installation. Contact our customer service representative for details.

STANDARDS: All Model 130 Series differential pressure gauges either conform to and/or are designed to the requirements of the following standards:

ASME B1.20.1
 ASME B40.1
 CSA-C22.2 No. 14.25 and 30
 EN-61010-1

NACE MR0175
 NEMA Std. No. 250
 SAE J514
 UL Std. No. 50,508 and 1203

Mid-West[®]
Instrument

6500 Dobry Dr. □ Sterling Heights, MI 48314 U.S.A.
 (586) 254-6500 □ FAX (586) 254-6509
 E-mail: sales@midwestinstrument.com
 Website: www.midwestinstrument.com

Printed in U.S.A.



REPRESENTED BY: