

## Model 142 “DELTA-METER” Diaphragm-Type Differential Pressure Gauge

**RANGE: 0-20 IN. H<sub>2</sub>O TO 0- 25 P.S.I.D.**

The Model 142 is ideally suited for use on dissimilar fluids, wet gas, or fluids with a high concentration of solids, etc. A few of its unique features are:

### Gauge Features

- Total separation of high and low pressures by a convoluted elastomer diaphragm.
- Range: 0-20 In. H<sub>2</sub>O thru 0-25 PSID  
(0-50 mbar thru 0 – 1.7 bar)
- AL & SS working pressure 3000 P.S.I.G. (207 bar)
- Brass working pressure 1500 PSIG (103 bar)
- Over-range protection to rated working pressure
- Aluminum, Brass, or 316 / 316L SS Gauge Body.
- Wetted 316 SS and Ceramic moving components.
- Standard weather-resistant construction.
- Accuracy  $\pm$  3-2-3 % standard.
- Optional Shatter Resistant lens
- 2 ½” and 4 ½” plastic dial assemblies.
- Optional 3 ½” & 4 ½” Anodized Aluminum dial assembly.
- Reverse pressure ports available.
- Five Year Limited Warranty.



4 ½” Dial

### Switch Features

- Up to two independent adjustable switch points.
- Hermetically Sealed Switch Outputs up to 0.5 amp in SPST configuration and up to 0.25 amp in SPDT configuration.
- SPST outputs available in Normally Open configurations.
- Switch Adjustable from 15% - 95% of Range
- Up to 240 VAC/VDC voltage ratings
- **CE** Marked to requirements of the Low Voltage Directive



2 ½” Dial with Switch

## 5 Year Limited Warranty

**Operation:** Differential pressure is sensed by flexible elastomer diaphragm and a calibrated range spring. A magnetic coupling transmits the sensing element motion to an indicating pointer. This prohibits the possibility of fluid leaking into the gauge case, while assuring total isolation of the process fluid within the pressure capsule. The diaphragm assures total separation between the high and low pressure signals. It is totally supported at full travel in either direction. The Model 142 is protected against over range to its rated working pressure

# Part Numbering System

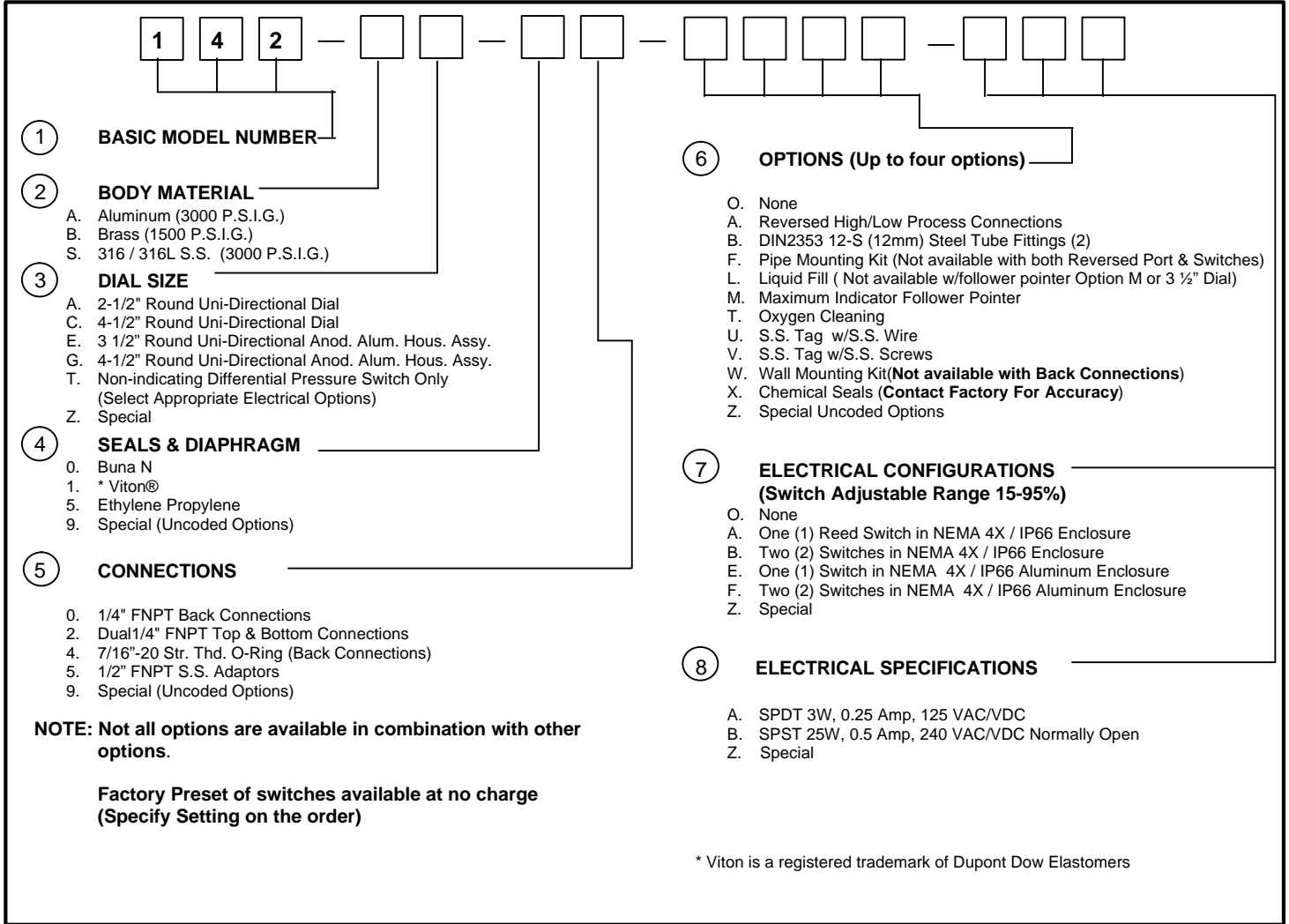

\* Viton is a registered trademark of Dupont Dow Elastomers

**PROOF PRESSURE:** Two times the working pressure or 6000 PSI, whichever is lower at ambient temperature.

**TEMPERATURE LIMITS:** -40 °F (-40° C) to 200°F (93°C). These limits are based on the entire instrument being saturated to these temperatures. System (process) temperatures may exceed these limitations with proper installation. Contact our customer service representative for details.

**STANDARDS:** All Model 142 Series differential pressure gauges either conform to and/or are designed to the requirements of the following standards:

- |                        |                      |
|------------------------|----------------------|
| ASME B1.20.1           | NACE MR0175          |
| ASME B40.1             | NEMA Sts. 250        |
| EN-61010-1             | UL Std. No. 50 & 508 |
| CSA-C22.2 No. 14, & 25 |                      |

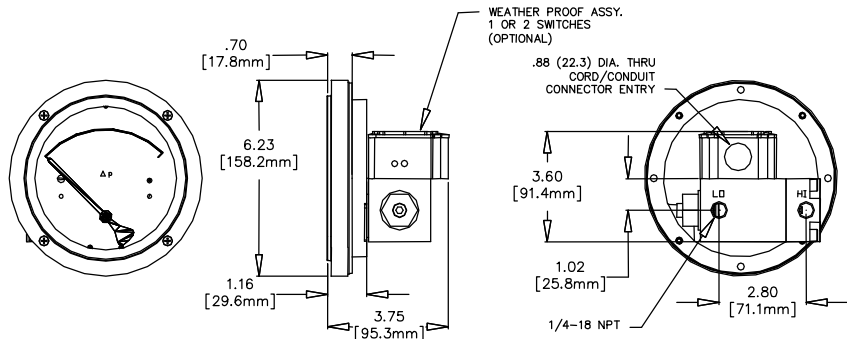
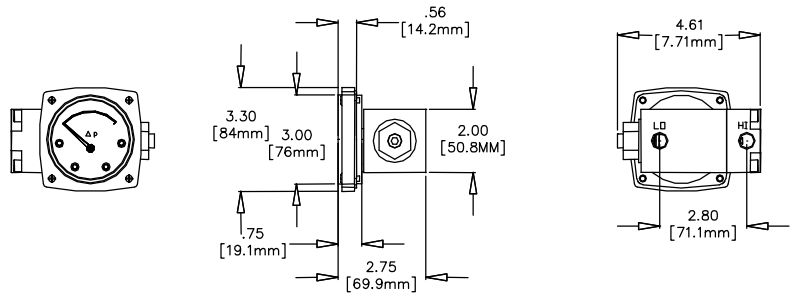

## Mid-West<sup>®</sup> Instrument

6500 Dobry Dr. Sterling Heights, MI 48314  
 Ph: (586)254-6500 FAX (586)254-6509  
 E-Mail: [sales@midwestinstrument.com](mailto:sales@midwestinstrument.com)  
 Web Page: [www.midwestinstrument.com](http://www.midwestinstrument.com)

