

1.0 SCOPE

These instructions provide procedures for installing the V100 Verabar flow sensor. Procedures are given for all industrial flow measurement applications including liquid, steam and gas service for both horizontal and vertical piping configurations.

2.0 RECEIVING INSPECTION

The following tasks should be performed as part of the receiving inspection procedure:

- Check items received against the packing list.
- Check sensor nameplate for proper model number, serial number and customer number.
- Verify that the actual pipe diameter matches the ID stated on the sensor nameplate.
- Check the bullet shaped sensor tube for any signs of damage. Damage to the sensor tube may result in erroneous flow readings.
- Check the round cover tube for any damage, especially axial gouges or scratches. Damage to the cover tube may prevent the ferrule from sealing properly.

3.0 SAFETY PRECAUTIONS

The following tasks should be conducted prior to installing the Verabar flow sensor:

- Check maximum operating conditions on the flow sensor nameplate and verify that they exceed the maximum conditions of the installation. If any pressure, temperature or flow limits will be exceeded, consult the factory before proceeding.

- Check that the pipe is depressurized and drained prior to installation.
- Check that all pressure containing components are properly installed and tightened prior to pressurizing the system.

4.0 INSTALLATION PREPARATIONS

4.1 Location

For the most accurate flow measurement, a minimum straight run of pipe is required. Table 1 shows the minimum straight run requirements. If longer straight runs are available, position the Verabar such that the ratio of upstream straight run to downstream straight run is approximately 4 to 1. If straight run lengths are less than the values stated in Table 1, consult the factory for additional accuracy and location information. For additional piping configurations, see Drawing SUB-4521.

Position straightening vanes such that the end closest to the Verabar is half way between the Verabar and the closest upstream configuration. For elbow installations, mount the Verabar in the same plane as the closest upstream elbow.

4.2 Orientation

Verify the proper sensor orientation by checking for an “-H” (horizontal piping) or a “-V” (vertical piping) in the model number on the Verabar name plate.

Piping Configuration	Dimension -A-		Dimension -B-	
	Without Straightening Vanes	With Straightening Vanes		
Elbow		7	7	3
Multiple Elbows in the Same Plane		9	9	3
Multiple Elbows in Different Planes		18	9	3
Reduction in Pipe Size		8	8	3
Increase in Pipe Size		8	8	3
Control Valve		24	9	4

Table 1. Straight Run Requirements

4.2.1 Horizontal Piping

For air or gas installations, mount the Verabar in the upper 160° of the pipe to allow any condensate to drain into the pipe (Figure 1). For liquid or steam installations, mount the Verabar in the lower 160° of the pipe. This allows any entrained air to bleed back into the pipe for liquid applications and allows condensate to collect in the instrument piping for steam applications.

4.2.2 Vertical Piping

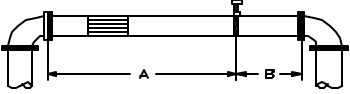
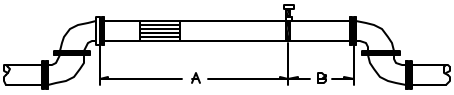
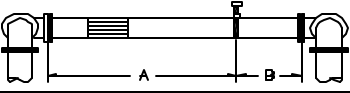
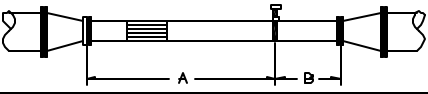
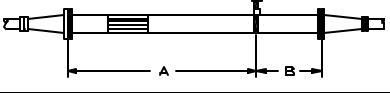
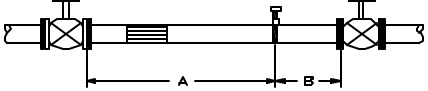
The Verabar may be mounted in any location around the circumference of the pipe for any vertical piping applications (Figure 1).

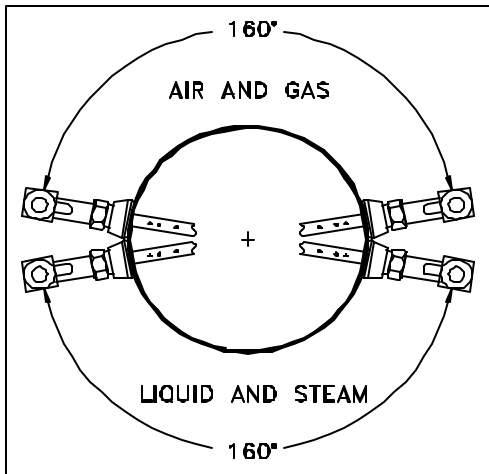

Figure 1. Verabar Orientation in Horizontal Pipe

4.3 DP Transmitter/Local Indicator Location

When choosing a Verabar location, consider the DP transmitter/local indicator location:

- The transmitter must be mounted below the Verabar for liquid and steam applications.
- The transmitter must be mounted above the Verabar for air and gas applications.

4.4 Installation Drawings and Bill of Materials

Additional information is available in the Installation Drawings and Bill of Materials VB-7061 (also on the VeraData CD). It contains standard and alternate transmitter locations and a complete bill of materials based on the fluid type and sensor orientation on the pipe.

5.0 INSTALLATION PROCEDURE

5.1 Drill Hole in Pipe

- Completely depressurize and drain pipe prior to installation of the Verabar.
- Mark the location of the hole through which the Verabar will be mounted. Use a center punch to mark the hole to prevent the drill bit from walking on the pipe.
- Drill the pipe with the proper sized hole per the following table:

Sensor Size	Hole Dia
V100-05	1/2" (13mm)
V100-10	1" (25mm)

- Deburr the hole on the inside of the pipe.

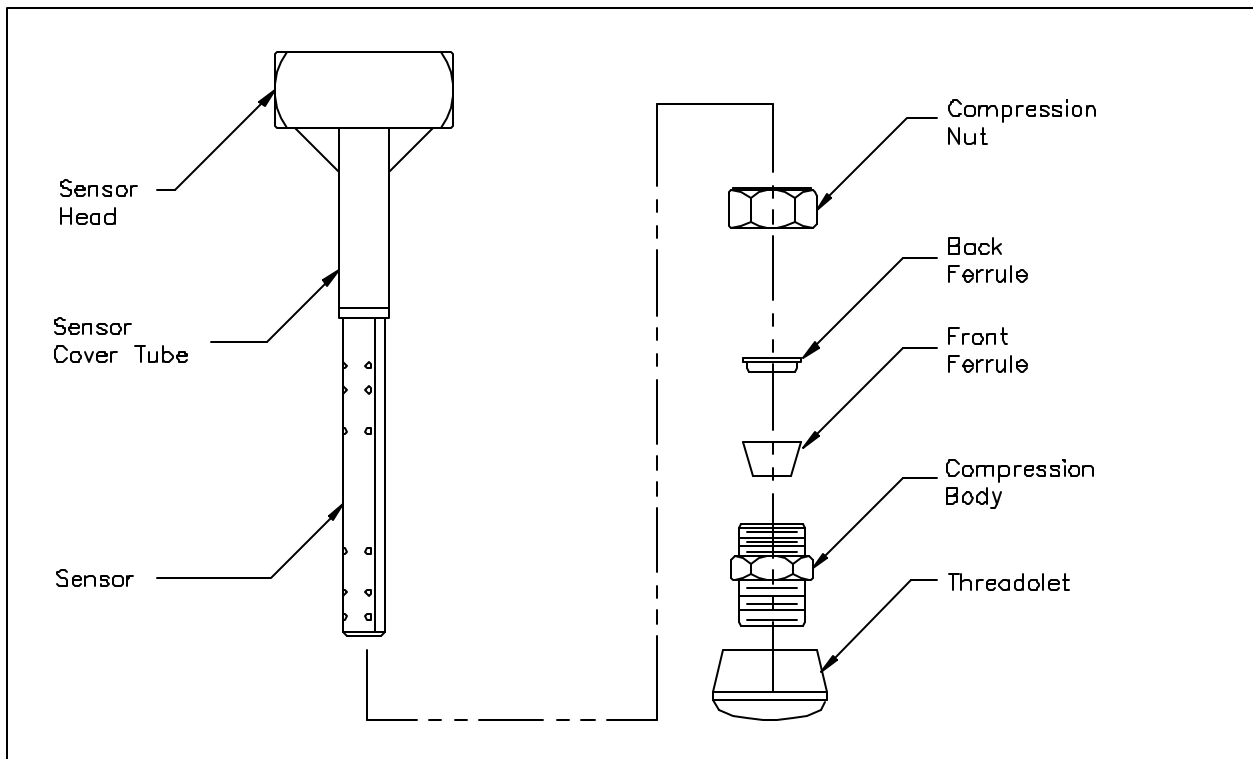

Figure 2. Verabar Model V100

5.2 Weld Threadolet to Pipe

- Loosely assemble the sensor, compression nut, back ferrule, front ferrule and compression body to the threadolet (hand tight) and insert the sensor assembly into the pipe. The back ferrule and front ferrule must be in the proper sequence and orientation as shown in Figure 2.
- Using the appropriate weld gap (1/16" [1.5mm] typical), tack weld the threadolet into position (Figure 3).

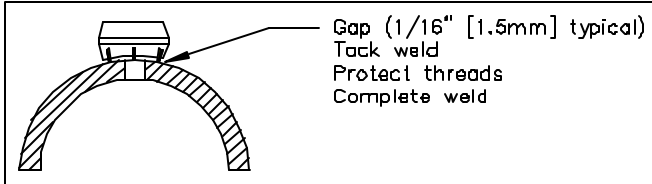

Figure 3. Weld Gap

- Remove the sensor, protect threads on the threadolet and finish welding the threadolet to the pipe per applicable piping codes.

5.3 Insert Sensor

- Using appropriate pipe thread sealant, install (completely tighten) the compression body into the threadolet.
- Slide the compression nut, back ferrule, then front ferrule, onto the sensor cover tube. **The back ferrule and front ferrule must be in the proper sequence and orientation as shown in Figure**

2. The back ferrule must be next to the compression nut with the tapered end pointing toward the front ferrule. The tapered end of the front ferrule must point towards the compression body.

- Slide the sensor, with compression nut and ferrules attached, into the compression body (do not tighten).
- Align the head of the sensor so that the arrow labeled "flow" on the head is in the direction of the flow in the pipe to within 3° (Figure 4). Maintain the head in this position for the remainder of the operations.
- While pushing the sensor against the opposite wall with a force of at least 50 lbs (22kg), tighten the compression nut 1-1/4 turns past hand tight.** This prevents vibration caused by the end of the probe lifting off the opposite wall of the pipe. A come-along, band clamp or strap wrench may be used for this operation.
- Reverify the alignment of the sensor such that the arrow labeled "flow" on the head is in the direction of the flow in the pipe to within 3° (Figure 4). A crescent wrench or pipe wrench can be applied to the head of the sensor to make alignment adjustments.

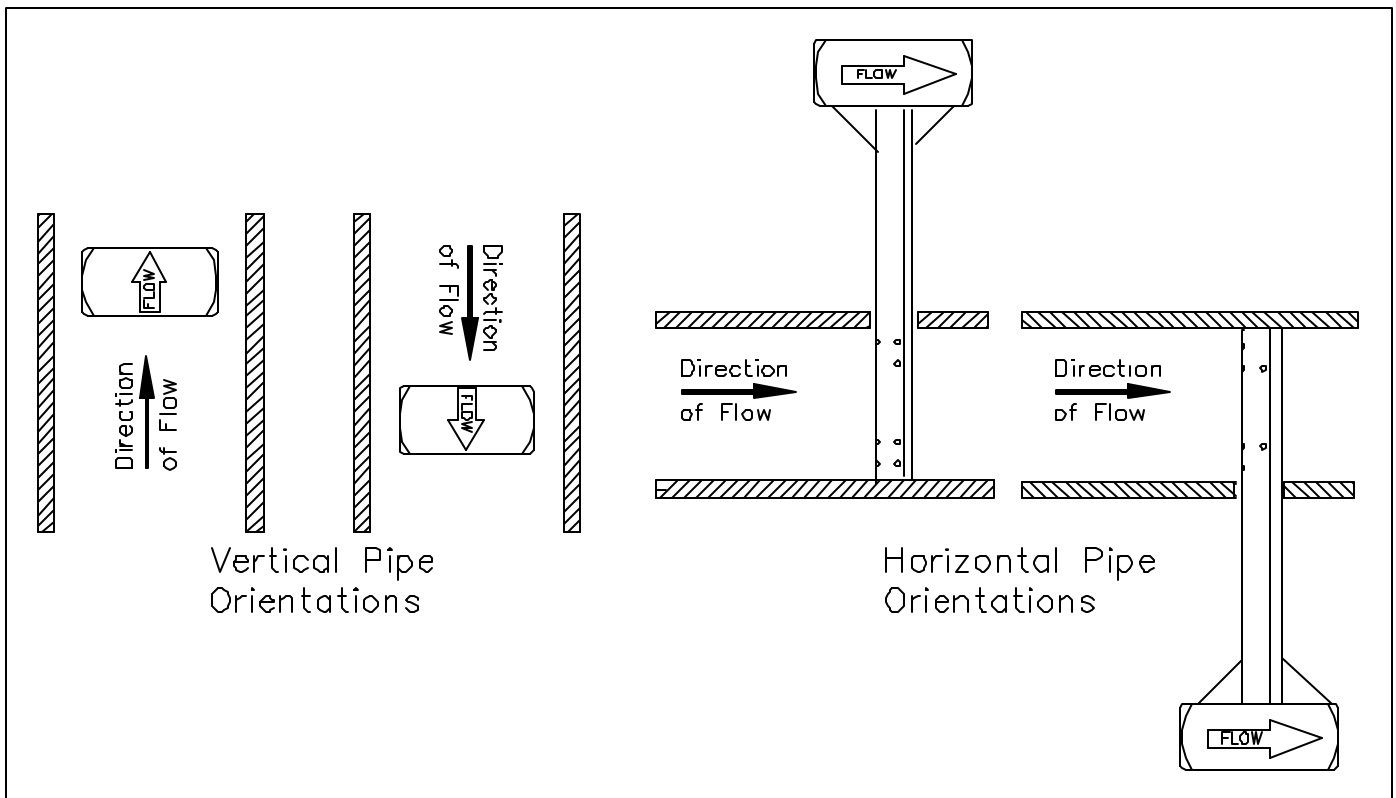

Figure 4. Orientation of Flow Arrow

5.4 Insert Instrument Valves or Manifold

5.4.1 Valves

If the Verabar does not have a valve head, install instrument valves using proper thread sealant. Be sure instrument shut-off valves are installed and shut prior to repressurizing the pipe.

5.4.2 Manifold

If the Verabar has a direct or integral manifold, be sure the high and low pressure block valves are shut off prior to repressurizing the pipe.

The Verabar is now properly installed (Figure 5).

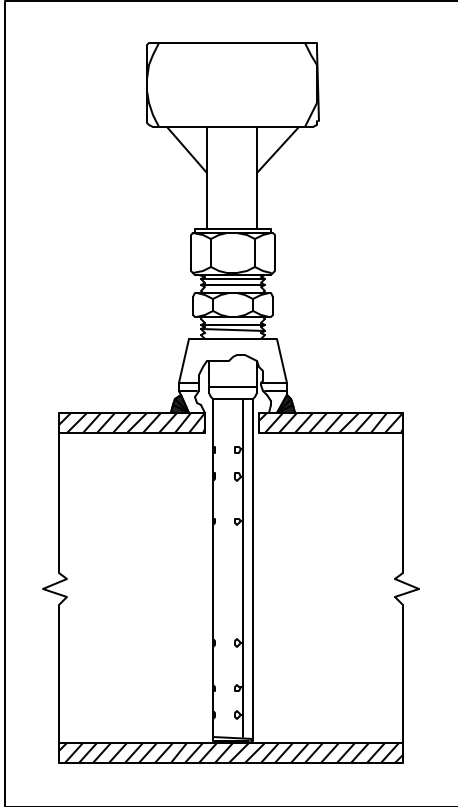

Figure 5. Installed V100

Periodic Maintenance

The assembly should be periodically checked. Verify that no leaks are present.