

Electrical Installation and Operating Instructions - Model 220



1. Safety

1.1 Specific Condition:

- A. The maximum gap permitted between the body and cover is less than the maximum permitted in the standard. Therefore, it is the responsibility of the user of this equipment to ensure the maximum gap between the body and the cover is not greater than 0.038mm (0.0015”).
- B. The Cover fasteners are of a non-standard production. For replacement purposes these fasteners shall be obtained from Mid-West Instrument only.
- C. The optional dial gauge may present a potential electrostatic charging hazard. Clean only with a damp cloth.
- D. Potential electrostatic hazards shall be addressed in accordance with the guidance given in the instructions below, and IEC TS 60079-32-1.



WARNING: *This product should be installed by personnel trained in installation of equipment in Hazardous Locations and meet the representative country's National Electrical Code.*

WARNING: Prior to installation the purchaser should make the manufacturer aware of any External effects or Aggressive substances that the equipment may be exposed to.

WARNING: Verify media compatibility of selected wetted materials of construction (body and elastomer). Chemical reaction / corrosion can cause premature failure of the pressure containing parts.

WARNING: *Electrostatic Hazard: The Lens and Plastic Bezel and Dial Chamber may present a potential electrostatic charging hazard. Clean only with a damp cloth. Do not use solvents*

WARNING: *Failure to connect to the protective conductor terminal may result in a shock hazard.*

WARNING: *To meet Hazardous Location's Requirements, torque the cover bolts to the specified values on the Ratings plate.*

WARNING: *The maximum gap permitted between the body and cover is less than the maximum permitted in the standard. Therefore, it is the responsibility of the user of this equipment to ensure the maximum gap between the body and the cover is not greater than 0.038mm (0.0015”).*

WARNING: *Do not scratch, nick, or dent mating surfaces of the gauge body and the cover during maintenance. The integrity of the flame-proof enclosure is dependent upon this metal to metal seal.*

WARNING: *The Model 220 product utilizes a piston design which inherently has a small amount of leakage from high process connection to low process (15 SCFH air max at 100 PSID) connection. Do not use this product in an application with the low side process connection left open to atmosphere.*

Electrical Installation and Operating Instructions - Model 220



CAUTION: *If cover bolts are lost or damaged, they SHALL be purchased from Mid-West Instrument for replacement. The bolts are non-standard and have been designed specifically for the referenced Hazardous Locations in this document.*

CAUTION: *Clean Metal joint area with non-abrasive cloth after any maintenance activity that requires the cover to be removed. A small amount of non-hardening grease may be applied in the joint area.*

CAUTION: *In dust environments some minor surface layering may occur. Routine cleaning shall be performed for removal of the dust layer.*

CAUTION: *This product utilizes a magnet as part of the sensing element. Magnet particles in the process can cause the piston to stick or become wedged in the bore.*

1.2 Intended use

The indicating / non-indicating differential pressure switches are used for monitoring differential pressures in industrial applications and/or Hazardous Locations as defined in this document.

The manufacturer shall not be liable for any claims if the product is used in applications contrary to the intended use.

1.3 Personnel

Personnel installing and putting this instrumentation into service shall be suitably trained and qualified in accordance with local codes, practices and regulations.

1.4 Labeling / Marking

The following Electrical Configurations bear this mark and comply with the relevant European Directives identified on the declaration of conformity: Configurations R, S.

See Figure 2 and Figure 4



In addition Electrical Configurations R & S also bear North American Markings Identified below for Electrical Configurations J & K. See Figure 1 and 3

The following electrical configurations bear 1 or both of these third-party listing agency marks for product evaluated to both US and Canadian Standards: A, B, J, K



2.0 General Specifications

2.1 Non-electrical

Table I -

Parameter	Division Classification Hazardous Locations Limits	ATEX / IECEx Hazardous Locations Limits
Working Pressure(PSI)	4000	2900
Proof Pressure(PSI)	16,000	
Temperature	T6 (T4A for Relay output)	T 6 (-40°C ≤ Ta ≤ 70°C)Gb T 5(-40°C < Ta < 85°C)Gb
Differential Pressure Range (PSID)	0-5 to 0 to 110	
Indicator Accuracy ASME B40.100	2%	
DP Over-Range	+/- Proof pressure	

Electrical Installation and Operating Instructions - Model 220

2.2 Electrical:

Table II

Parameter	Switch Specification			Relay Output
	SPST	SPDT	SPDT	SPDT/ DPDT
Electrical spec	A	A	A	B,C,D,E,F,G,H
Output Option Code	E ,F,G	H	A	R
*Power	60 W	60 W	3W	N/A
Max. Current	3.0 Amps	1.0 Amps	0.25 Amps	10 Amps
Max. Voltage VAC/VDC	240	240	125	277/30
Setting (%F.S.)	15 to 90	25 to 90	10 to 90	15 to 90
Hysteresis (Max/Nom)	20% / 10% (F.S.)	20% / 18% (F.S.)	10% / 6% (F.S.)	20% / 10% (F.S.)
Repeatability	1% F.S.	1% F.S.	1% F.S.	1% F.S.

*

Product of the switching voltage and current shall not exceed the power rating of the device.

3.0 Product Description:

Differential pressure is sensed by the movement of a floating piston magnet against a calibrated spring. The magnetically coupled gauge pointer located outside the pressure housing follows the movement of the piston magnet and indicates differential pressure on the dial. The switches are also magnetically operated and are located outside of the pressure housing. The switches are mechanically adjustable allowing the customer to set the switch within a defined adjustment span of the range of the instrument.

This instrument is mainly intended for gas / air / oil applications.

4.0 INSTALLATION:

4.1 INSPECTION: Upon receipt of your order, please review the ratings plate to verify that the model number and the electrical ratings match the product that you ordered. Electrical configuration option R & S units are CE marked in accordance with the ATEX directive and Kosha marked. In addition, the units will carry 3rd party markings per the Division classification system.

Please read the Cautions listed on the Rating Plate as they are different for each Electrical Configuration. The markings and warnings identified on each plate are applicable only to their respective Hazardous Locations classification. Ie; if the assembly is installed in an ATEX classified location, then the ATEX ratings plate shall govern.

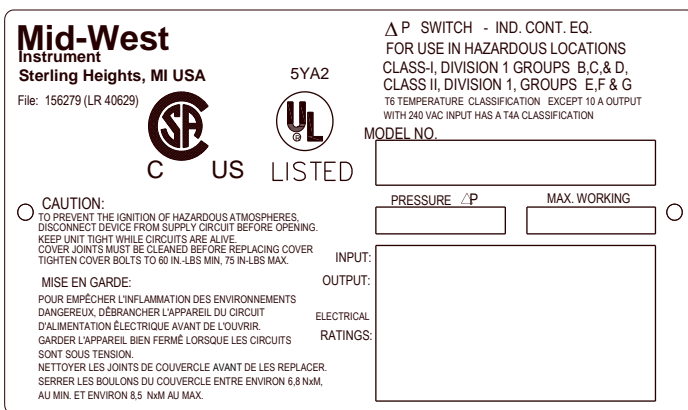

Figure 1

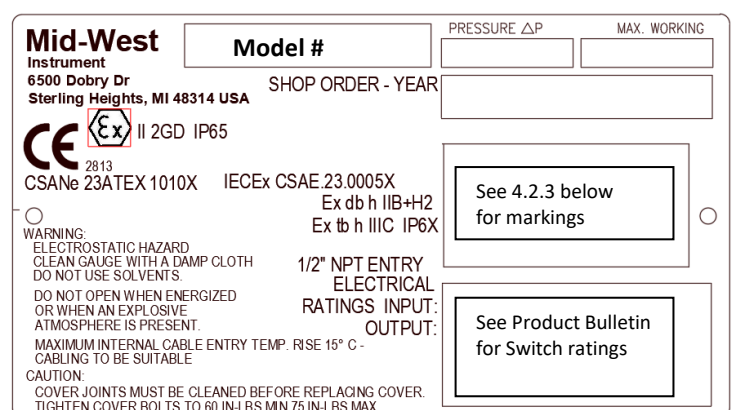

Figure 2

Electrical Installation and Operating Instructions - Model 220

INSPECTION (CONT.)

Figure 3

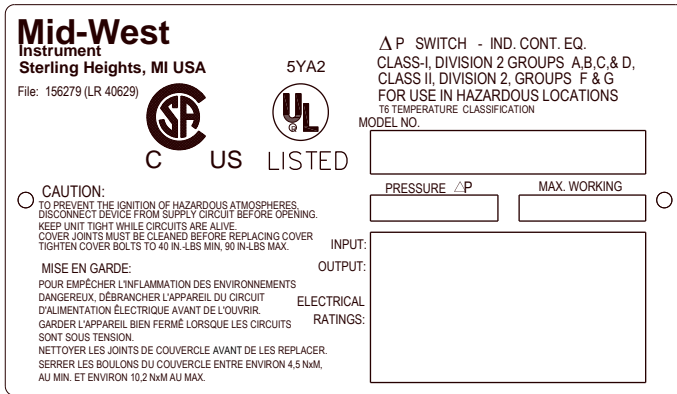

Figure 4



4.2 Hazardous Locations



- 4.2.1 Division 1 Locations:** Electrical Configurations J, K, R & S are 3rd Party Certified for Class 1, Division 1, Groups B, C & D; Class 2, Division 1, Groups E, F, & G Hazardous Locations. **All Electrical Specification Input & Output Combinations are approved for this classification. This enclosure does not have a NEMA 4X rating.**

This configuration has T6 Temperature classification for all input and output combinations except for the H input option which has a T4A Temperature classification.

For Electrical Specification Input Option A in combination with Output Options A through H, a seal is not required.

For Electrical Specification Input options B through H in combination with Output option R, a seal is required within 18" of the enclosure. Please refer to National Electrical Code requirements.

- 4.2.2 Division 2 Locations:** Electrical Configurations A & B (without Relay Output) are 3rd Party Certified for Class I, Division 2, Groups A, B, C, & D; Class 2, Division 2 Groups F & G Hazardous Locations. **Only Electrical Specification Input Option A in combination with Output Options A through H are approved for this location. This enclosure does have a NEMA 4X rating.**

- 4.2.3 ATEX Locations:** Electrical Configurations R & S are ATEX and IECEx Certified for Gas & Dust Atmospheres as: (Group II Category 2 Gas & Dust Atmospheres)

Electrical input options A in combination with Electrical Output options A, E, & H.)

Ex db h IIB + H2 T 6 (-40°C ≤ Ta ≤ 70°C)Gb
 T 5(-40°C < Ta < 85°C)Gb
 Ex tb h IIIC IP65 * T85°C (-40°C ≤ Ta ≤ 70°C)Db *++
 T100°C (-40°C < Ta < 85°C)Gb *

 II 2GD IP65



Electrical Installation and Operating Instructions - Model 220

Electrical Input options B thru G in combination with Output Option R.

Ex db h IIB + H2 T 6 (-40°C ≤ Ta ≤ 70°C)Gb
Ex tb h IIIC IP65 * T85°C (-40°C ≤ Ta ≤ 70°C)Db *
 II 2GD IP65

Ex db h IIB + H2 T 6 (-40°C ≤ Ta ≤ 70°C)Gb
Ex tb IIIC IP65 * T85°C (-40°C ≤ Ta ≤ 70°C)Db *
 II 2GD IP65

Electrical input option H in combination with Electrical Output option R.

Ex db h IIB + H2 T 4 (-40°C ≤ Ta ≤ 70°C)Gb
Ex tb h IIIC IP65 * T135°C (-40°C ≤ Ta ≤ 70°C)Db *
 II 2GD IP65

* Excluded from Kosha Approval. Ex tb IIIC ratings are not applicable in Korea.

4.3 Installation Tools

8mm deep metric socket.
Torque wrench
Adjustable or 1.125" wrench (process connections)

WARNING: *Verify media compatibility with all wetted parts. Range spring is manufactured from 316SS. Media incompatibility with the spring or the body of the gauge can result in an ignition hazard due to corrosion.*

CAUTION: *Do not exceed the maximum rated working pressure stated on the ratings plate.*

CAUTION: *Always use a wrench (1.125") on the switch's process connections to keep them in place while loosening and tightening customer supplied process fittings.*

CAUTION: *Use pressure limiting devices to limit pressure spikes below the proof pressure of the gauge / switch.*

Perform all electrical adjustments with power removed.

4.4 Instrument Location:

On liquid service the instrument should be mounted **below** the process connections to facilitate self-bleeding. On gas service it should be located above the process connections to promote self-draining. If the process contains particulates, a pigtail loop or drop leg (manometer "U-tube" configuration) in the tubing will minimize the possibility of it migrating into the instrument.

4.5 Mechanical Connections:

Connections are either ¼" FNPT or ½" FNPT dependent upon the option selected when the order was placed. There are 2 connections identified on the gauge body as "High" and "Low" for High pressure and Low pressure respectively. Be sure these are plumbed properly in your system. Improper connection will not damage the instrument; however, the switch and indicator (if supplied) will not function properly.



Do not allow gauge fittings to rotate when making process connections. Calibration and / or pressure rating of the product may be compromised.

Electrical Installation and Operating Instructions - Model 220

4.6 Temperature Limitations:

Process: For process temperatures higher than the rated temperature of the dp gauge / switch, use process tubing to reduce the temperature. A general “rule of thumb” is that for horizontal tubing runs the temp drop is 100° F/ ft. Another option is to use “cooling towers” to protect the instrument.

Verify the selected elastomer option is appropriate for your operating temperature.

Environment: Locate unit where temperatures will be within the limits of the instrument’s hazardous locations ratings.

4.7 Mounting:

Pipe Mounting: Configuration of the pipe mount option is shown below:

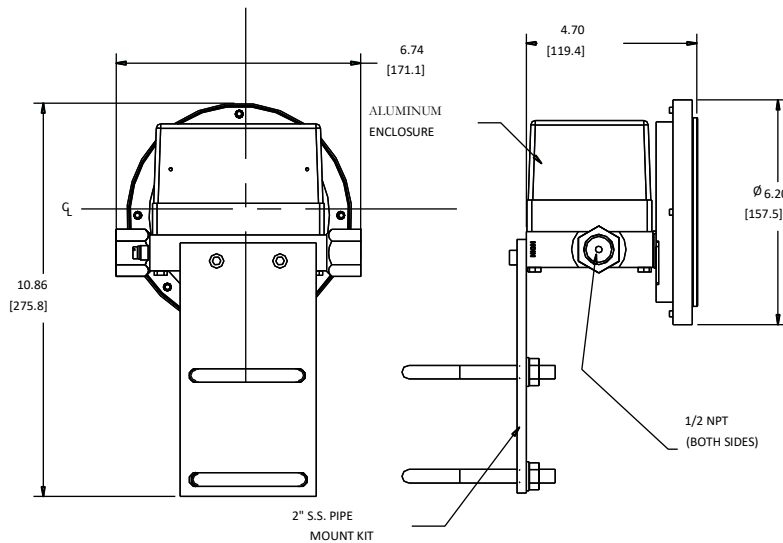

Figure 5 Typical SS 2" Pipe Mounting

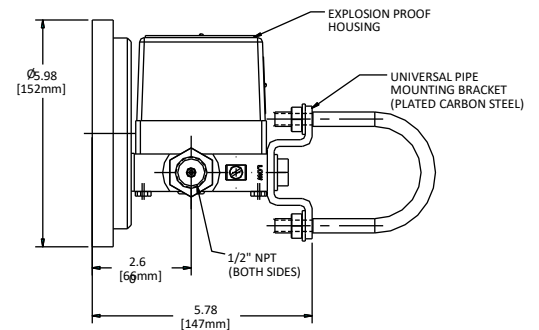

Figure 6

Typical CARBON Steel 2" Pipe Mounting

Mounting Holes: The instrument is provided with two(2) 5/16-24 mounting holes on the back of the body. They are spaced 1.75" and are tapped a minimum of 6.2 threads deep. A customer selected bolt must allow for 1 free thread after full engagement with the gauge body.

4.8 Electrical Connections:



CAUTION: Use cable suitable for the specified temperature class. Maximum internal cable entry temperature rise is 15 °C – Cabling to be suitable.

WARNING: Electrical connection shall be made with a cable entry or stopping box certified for use for the desired hazardous location, certified for condition of use, and correctly installed. The cable entry device and any thread adaptor shall be suitable for the equipment, the cable, and the conditions of use, and shall be certified as equipment (Not an EU component) under the EU Type Examination Certificate to directive 2014/34/EU. (Latter Statement ATEX applicable)

WARNING: When used in an explosive dust atmosphere, the cable entry device and thread adaptor shall maintain the ingress protection of the enclosure.

Electrical Installation and Operating Instructions - Model 220

WARNING: *During maintenance do not disconnect from external earth conductor until all power generation systems have been turned off.*

WARNING: *In Hazardous Locations remove power from the unit before removing the cover.*



WARNING: *Do not touch the surface of the printed circuit board if the unit is powered. High Voltage may be present.*

Warning: *Electrical connections should be performed by qualified personnel and meet the representative country's national electrical code.*

Warning: *Perform all switch adjustments with power removed. Use an ohmmeter or equivalent to monitor contact operation.*

Caution: *Preference should be given to setting the switch prior to installation. It is also recommended to perform adjustments using a non-magnetic screwdriver.*

4.8.1 Cover: Remove the cover by using an 8mm hex driver to loosen the bolts from the underside of the gauge body. (see previous cautions and warnings). The bolts are captive in the body of the gauge. A deep metric socket is recommended in order to clear interference near the bezel of the gauge. (0.48 diameter min 1" long).

The cover is often shipped with only 4 screws threaded into the body of the gauge to save time for the customer when installing the assembly. When closing the cover all 7 screws need to be tightened to the torque requirements defined on the external tagging and this instruction.

For the non-gasketed assembly, clean both mating metal surfaces prior to re-assembly (see previous cautions and warnings). A small application of a suitable, non-hardening grease may be applied to the mating metal surfaces. Replace cover making sure there are no wires pinched between the cover and the gauge body. Re-tighten the screws within the range defined on the Model # Tag.

4.8.2 Connections: Connections to the terminal strip are identified in the following sections. The terminal strip is compatible for wire ranges from 12-22 AWG (3.3 - .32 mm²). Optionally, each connection can be field wired with multiple wires connected to one contact. You may connect two (2) 22 – 16 AWG (0.33 -1.3 mm²) wires into one connection. Recommended screw torque is 6 in.-lbs. (0.113 newton-meter) to tighten the terminal strip screw.

4.8.3 Switch Set Point Adjustment



Do not use excessive force when rotating the adjustment screw as the adjustment mechanism may be damaged.

Note: *Switches can be set below the defined minimum set point however, the switch may not remain activated at maximum PSID. If the unit is set below the defined minimum set point, the customer should verify that the switch remains activated from the set point to over range of the gauge.*

All switch types are field adjustable. The defined range of the adjustment is specified in Table I above. All switches come with a decal to identify adjustment direction to increase the set point. **Do not use excessive force when rotating the adjustment screw as the adjustment mechanism may be damaged (See Figure 9).**

The switch may be set using the indicating dial as a reference (units with a dial) or by using a reference pressure gauge.

Electrical Installation and Operating Instructions - Model 220

For setting on increasing pressure increase your pressure to the desired set point. Increase the switch set point above the desired switch set (switch deactivated). Slowly decrease the switch set point until the contact activates.

4.8.4 Contact Protection:

Provide standard protection techniques for the switch contacts for capacitive and inductive loads. Use current limiting techniques near the switch to protect the contacts due to high inrush (i.e.; in line resistor or inductor) for long cable interfaces. Provide clamping devices at or near inductive loads (i.e.; relay).



Maximum wire length between the 3W switch and its load should not exceed 70 – 100 Feet for 120 VAC applications. We recommend that you use the 60W rated switches or use a current limiting resistor wired in series and located near the switch. Contact the factory for assistance regarding this condition. (For hazardous Locations the resistor option is not allowed)

Warning: Please verify use of added devices for applicability in hazardous locations.

4.8.5 Hermetically Sealed Switch Outputs:

Electrical Specification Input Option “A” (2nd letter for Electrical Options) identifies that your unit does not need input power to operate the switch output and that your unit is equipped with Hermetically Sealed Reed switches. The “A” option matched with Output Options A, E, F, & H identifies the output switching capability of your unit. Depending on the electrical configuration specified on the order (A, B, J, K, R, or S), your unit will be equipped with 1 or 2 independently adjustable reed switches.

Customer Interface to the 16 position terminal strip shown in Figure 7 is defined in Table III.

Electrical Options	Sw. Qty	Function	Terminal Connections	
			Switch Adjust Low Port	Switch Adjust Hi Port
AAA, JAA, AAH, JAH RAA, RAH	1	SPDT	1(COM), 2(NO), 3 (NC)	No Connection
BAA, KAA, BAH, KAH SAA, SAH	2	SPDT	1(COM), 2(NO) 3 (NC)	8(COM), 7(NO) 6 (NC)
AAE, JAE, RAE	1	SPST NO	1,2	No Connection
AAF, JAF, RAF	1	SPST NC	1,3	No Connection
BAE, KAE, SAE	2	SPST NO	1,2	8,7
BAF, KAF, SAF	2	SPST NC	1,3	8,6
BAG, KAG SAG	2	SPST 1 NO, 1NC	1, 3 NC	8, 7 NO

Table III

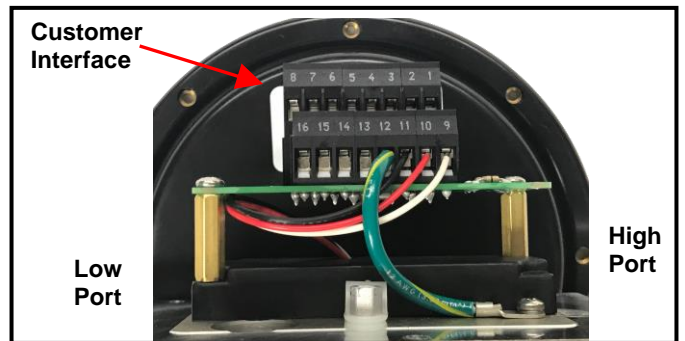

Customer Chassis connection is to position 13

Figure 7

Customer Interface for the Reed Switch Output Option will be via connections 1 through 8 and connection 13. Do not loosen the connections at positions 9, 10, 11, 12, 14, 15, or 16.

Electrical Installation and Operating Instructions - Model 220

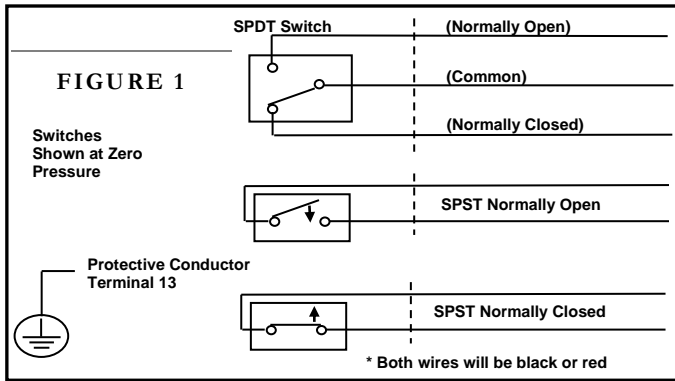
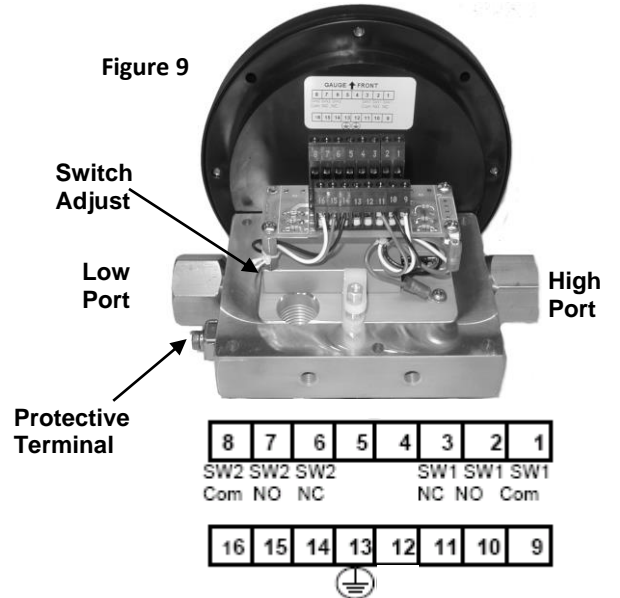

Figure 8



4.8.6 Relay Output Interface

Electrical Specification Input Option “B” through “H” identifies that your unit will need input power to operate the relay output (output option R). Depending on the electrical configuration specified on the order (A, B, J, K, R, or S) your unit will be equipped with 1 DPDT output or 2 independently adjustable SPDT relay outputs. Table I identifies the load ratings and the adjustability range of the output.

Interface to the 16 position terminal strip is defined in Table iv. Figure 10 identifies the wiring decals for DC and AC Inputs for the Relay output.

The relay outputs are uncommitted and may be connected to any load provided the load is within the output ratings of the relay. The terminal strip is compatible with 22 – 12 Awg. wire.

Electrical Options	Sw. Qty	Func.	Terminal Connections					
			Switch Adjust Lo Port			Switch Adjust Hi Port		
			Com	NO	NC	Com	NO	NC
A*R J*R R*R	1	DPDT	1	2	3	X	X	X
B*R K*R S*R,	2	SPDT	9	10	11	8	7	6

Table iv

*= Input Power Options B, C, D, E, F, G, & H

Input Power = Position 4 + for DC; Hot for AC
Position 5 Rtn. for DC, Neutral for AC

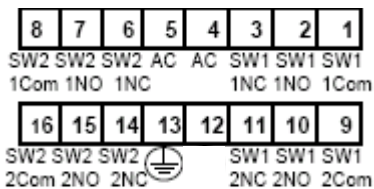

Relay Output - AC Input

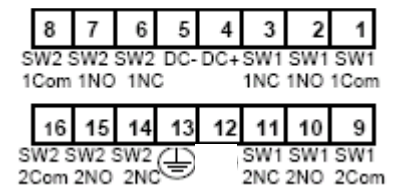

Relay Output - DC Input

Electrical Installation and Operating Instructions - Model 220

5.0 Dimensions:

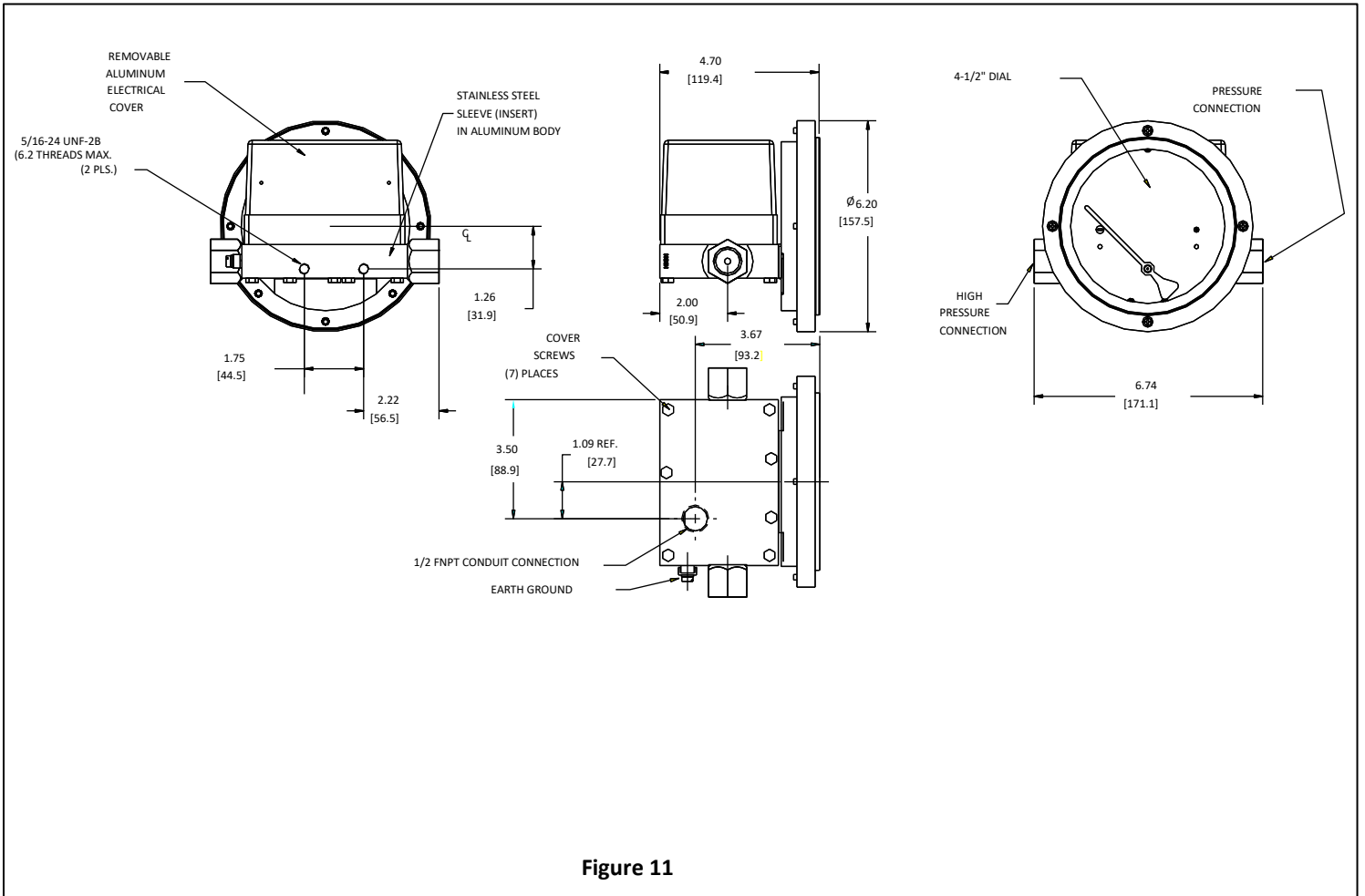

Figure 10

6.0 Troubleshooting

- A. Gauge accuracy and set point problems:
- i. Verify your process connections are plumbed properly. Check for proper connection to "hi" and "lo" ports.
 - ii. Make certain block valves are open and, if using a 3-valve manifold, that the equalizer (balance) valve is closed.
 - iii. If I and ii check out correctly, loosen or disconnect the high pressure line to determine if there is pressure to the instrument.
 - iv. Verify gauge is not in an electromagnetic / magnetic environment. i.e.; close proximity to high current power lines.
 - v. Verify the pointer has fluid movement as pressure increases. Jumpy movement or no movement may indicate a stuck piston
- B Switch doesn't function
- i. Make sure you have supplied power (proper voltage) to the unit if you ordered the power relay unit. The reed switch output units do not require power.
 - ii. Check that you are wiring to the correct interface terminals.
 - iii. Check the reed switch interfaces to the terminal board for loose connections. For the power relay the reed switch(es) connect to the terminal strip on the underside of the PCB. For the reed switch outputs the reed switch(es) connect to positions on the bottom row of the terminal strip on the top of the PCB (see Figure 4).
 - iv. Make sure that the switch load does not exceed the specified wattage rating of the switch. (steady-state and transient). Contact factory for assistance for excessive loads, otherwise proceed to the next step.
 - v. Perform a continuity check of the switch contacts by trying to actuate the switch using an external magnet. An operational switch usually indicates a problem with the gauge. If not operational proceed to the next step.
 - vi. Verify the reed switch wires are connected to the terminal strip (NEMA 4X enclosure only). Contact the factory for assistance if the switch is connected and/or request an "RGA" number.
 - vii. All others contact the factory for assistance.

Remaining media may result in a risk to personnel, environment etc. Use sufficient precautionary measures when removing and transporting the product.

7.0 Misc:

CE Marking Statements:

ATEX Directive 2014/34/EU

See Markings and ratings in section 4.2.3

Electrical Installation and Operating Instructions - Model 220

Pressure Equipment Directive :

The Pressure Equipment Directive has been determined to be **non-applicable for CE marking for Group 1 applications below 200 bar or Group 2 applications below 1000 bar**.. These products are manufactured in accordance with article 3, paragraph 3 of the directive, “sound engineering practice”. They fall below category I for non-hazardous gases, hazardous liquids, & non-hazardous liquids. This product also falls below category I for hazardous gases at or below 200 bar.

For Group 1 applications above 200bar, this product has not been evaluated to meet the essential safety requirements of Annex I of the Pressure Equipment Directive. Use of this product in an EU member state shall be limited to less than 200 bar for Group 1 applications.

ROHS Directive:

The electrical Configurations R & S are CE marked in compliance with the *RoHS3 Directive EU 2015/863*. See accompanying Declaration of Conformity (DOC) that ships with every product for more detail.

Warning: *The suitability of the application and installation of this differential pressure switch / transmitter is the responsibility of the end user. The applicable certifications, listings apply to the differential pressure switch / transmitter only.*

STANDARDS: The Model 220 Series differential pressure gauges either conform to and/or are designed to the requirements of the following standards:

ASME B1.20.1	ASME B40.1
NEMA Std. No. 250	SAE J514
CSA-C22.2 No. 14, 25, and 30	EN / IEC 60079-0, 60079-1
UL Std. No. 50, 508, 698, and 1203	EN / IEC 60079-31,
ISO 80079-36:2016	EN50581