

Installation and Operating Instructions - Model 130

1. Safety



Before installing verify compatibility to the process media and temperature in contact with the wetted parts. Incompatible media and / or operation at temperature extremes can cause premature degradation of materials which could result in safety risk to personnel.

Verify the selected pressure range (differential pressure and working pressure) and the switch ratings are within specification for your application.

Warning! Remaining media may result in a risk to personnel, environment etc. Use sufficient precautionary measures when removing and transporting the product.

1.1 Intended use: The indicating / non-indicating differential pressure switches are used for monitoring differential pressures in industrial applications. The manufacturer shall not be liable for any claims if the product is used in applications contrary to the intended use.

1.2 Personnel: Personnel installing and putting this instrumentation into service shall be suitably trained and qualified in accordance with local codes, practices and regulations.

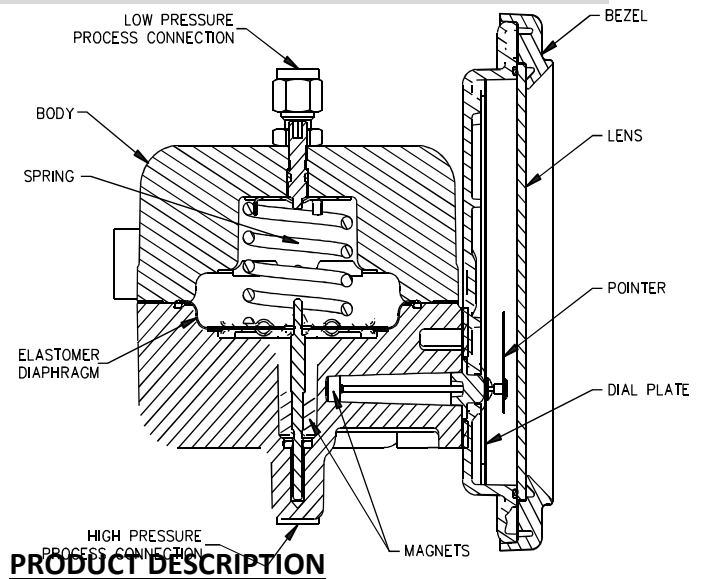

PRODUCT DESCRIPTION

The Model 130 is a differential pressure instrument available as a switch, gauge, or both. A flexible elastomer diaphragm and calibrated range spring are moved by differential pressure. A magnet, coupled with the diaphragm, transmits motion through the wall of the pressure housing to a follower magnet attached to an indicating pointer. The rotation of the follower magnet causes the pointer to track movement of internal driver magnet and indicate differential on the dial scale.

When equipped with switches for Aluminum, Brass or 316SS bodies only, a contact is made or broken by the magnetic field of the internal magnet. See Bulletin ELECIM130/latest for gauges with switches.

The diaphragm is totally supported upon reaching full travel in either direction, providing full over-range protection to rated working pressure.

INSPECTION

Before installation check the product label on each instrument against the receiving paperwork and the intended application for correct part number, materials of construction, working pressure, dial range, etc. If equipped with switches, check electrical rating, type of enclosure, etc. Inspect for shipping damage and, report it immediately.

Installation and Operating Instructions - Model 130 Series

NOTE - Before attempting repairs contact your local Mid-West Representative or our factory. Failure to do so will void any warranty.

INSTALLATION

Model 130 is calibrated and tested prior to shipment and is ready for immediate installation. Use of the following installation procedures should eliminate potential damage and provide optimum trouble-free operation.

1. CONNECTIONS

Model 130 P is provided with ¼" compression tube fittings, one low and one high, on the top and bottom of gauge body.

Model 130 A, B, S, is provided with **dual** ¼" FNPT connections top and bottom as standard. One pair of high and low pressure ports is for process connections.

Ports are identified for high and low pressure. Be sure to plumb to proper connections and system. Improper connection will not damage instrument but it will not function properly.

Flexible tubing is recommended to minimize effect of any vibration that may exist.

When attaching connections to the 130 P, care must be taken to prevent over-tightening which may result in stripping threads and/or cracking ports. In order to prevent this, use a suitable wrench to hold the factory supplied fitting in place while tightening, sometimes called "double wrenching".

2. INSTRUMENT LOCATION

It is recommended that installation is no closer than one inch of a steel surface otherwise accuracy will be affected. On liquid service, the instrument should be mounted **below** the process connections to facilitate self bleeding. On gas service, it should be located **above** the process fluid. If the process contains particulates, a "pigtail" loop or drop leg (manometer "U-tube" configuration) in the tubing will minimize the possibility of it migrating into the instrument.

NOTE – On liquid applications, unequal liquid heads on high or low side will result in an inaccurate differential pressure indication.

3. PANEL MOUNTING

The Model 130 is designed for mounting through the **front** of the instrument panel and is provided with a panel mount kit, consisting of four panel mounting studs/nuts.

Make cutouts as indicated in figure shown. Insert panel mounting studs, finger tight, into metal inserts located in the rear of the bezel.

Insert gauge through the panel, aligning panel mounting studs with holes in the panel. Install #8-32 nuts onto studs and tighten securely.

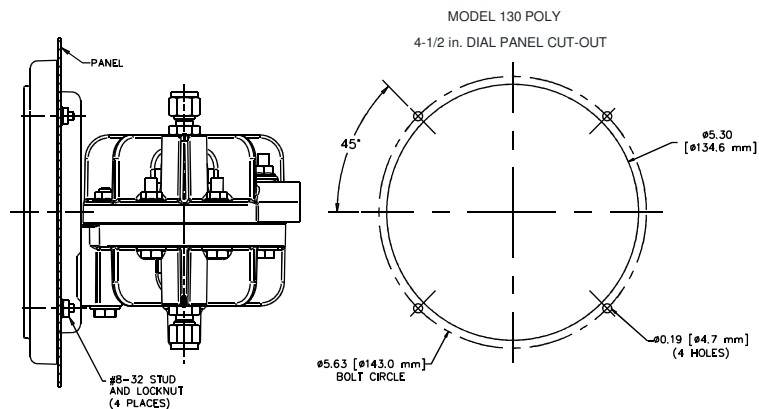

4. PIPE MOUNTING

If specified, your Model 130 will have a pipe mount kit installed. This provides for mounting on a 2" vertical or horizontal pipe.

TROUBLE SHOOTING

1. Gauge does not indicate differential

- A. Check for proper hook up, high to "HI" and low to "LO"
- B. Make certain block valves are open and, if using a 3-valve manifold, that the equalizer (balance) valve is closed.
- C. If A & B check out correctly, loosen or disconnect the high pressure line to determine if there is pressure to the instrument.
- D. If there is pressure to the instrument, check to determine that there is differential across the unit being monitored. If so, contact the factory for assistance and/or an "RGA" (return goods authorization) number to return the instrument for repair or replacement.