

MODEL 105 DIMENSIONS

DIAL SIZE	DIAMETER C Inch (mm)	LENGTH L Inch (mm)
4-1/2 in.	6.21 (157.7)	5.73 (145.5)
6 in.	8.18 (208.0)	5.79 (147.1)

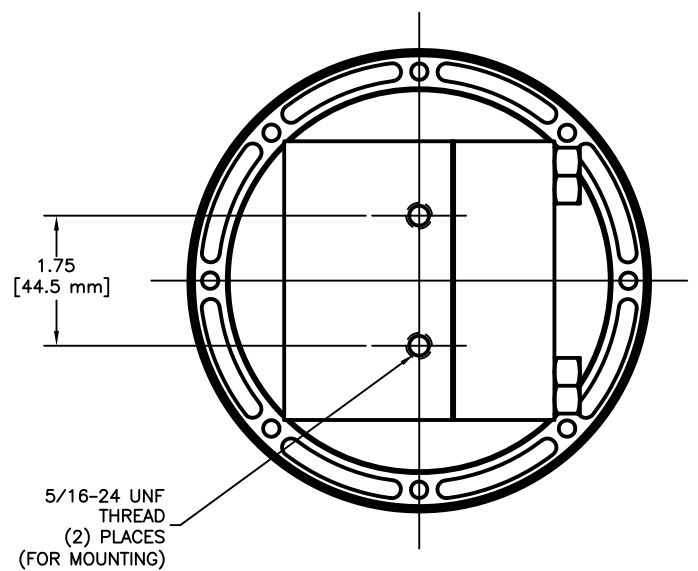

2 INCH PIPE MOUNT (FOR VERTICAL OR HORIZONTAL PIPE)
 CARBON STEEL

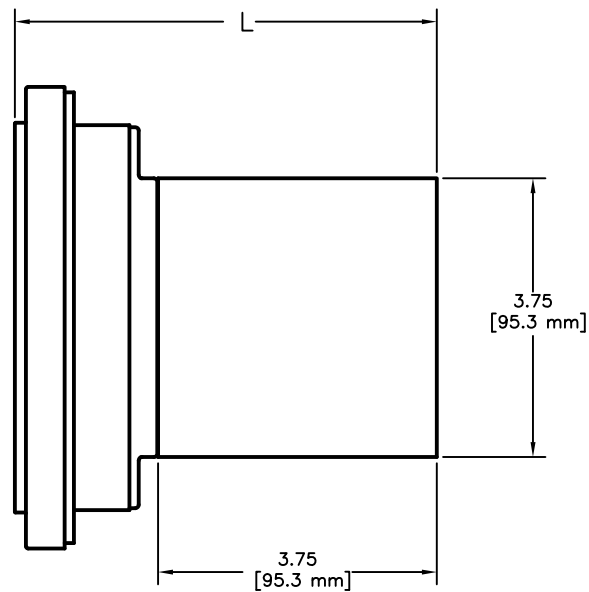
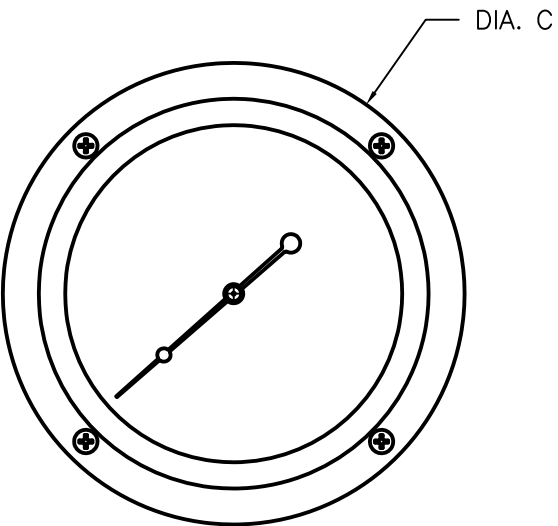
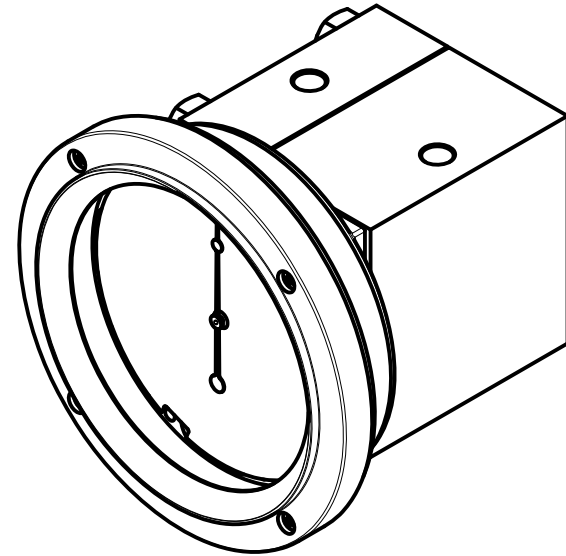
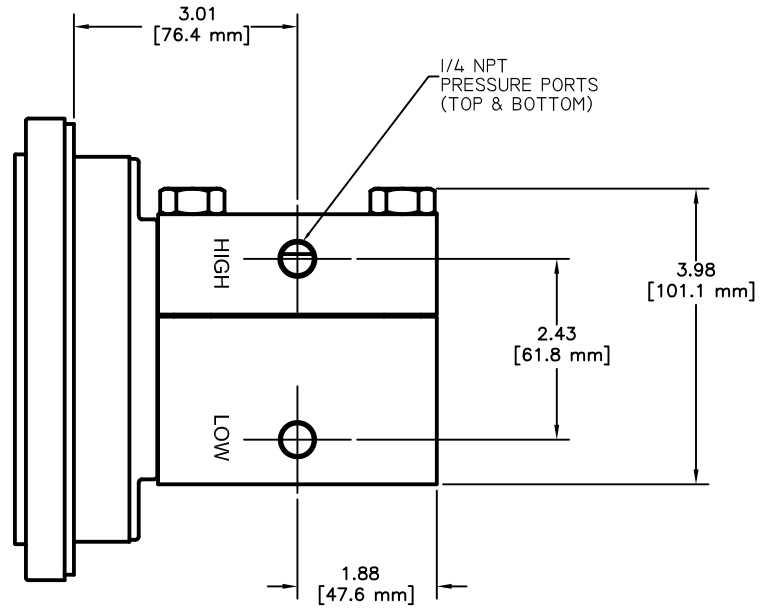
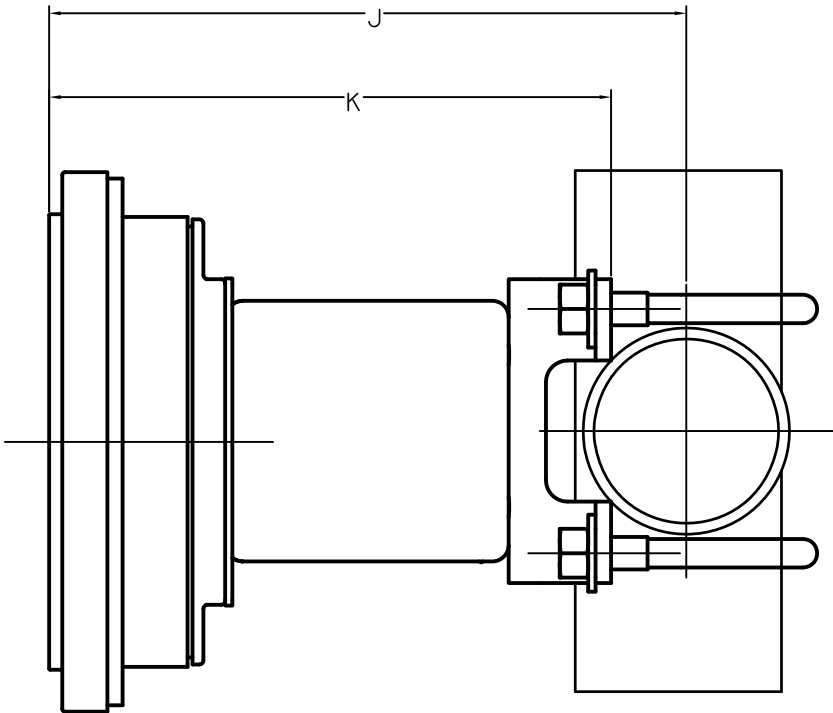
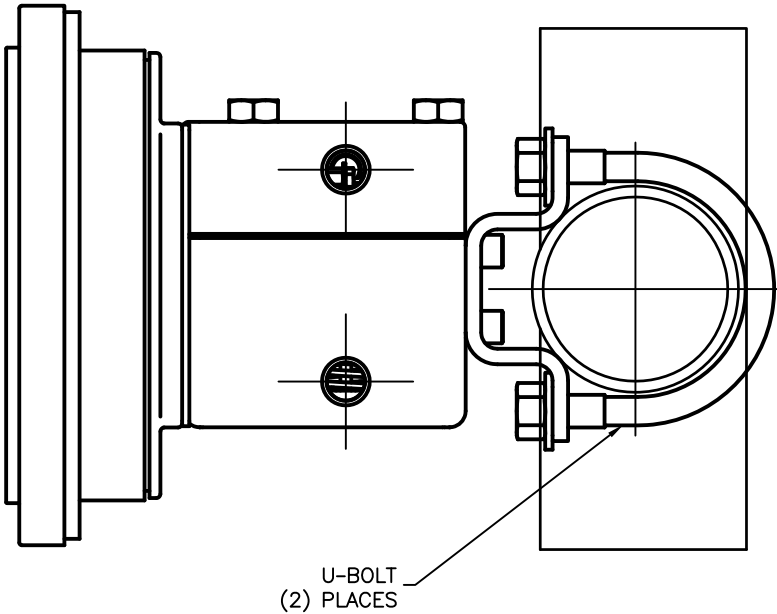

MODEL NO.	DIAL SIZE	LENGTH J Inch (mm)	LENGTH K Inch (mm)
105	4-1/2 in.	7.62 (193.7)	6.90 (177.2)
	6 in.	7.74 (196.7)	7.02 (178.5)
106	4-1/2 in.	7.14 (181.5)	6.42 (163.2)
	6 in.	7.26 (184.5)	6.54 (166.3)

2 INCH PIPE MOUNT (FOR VERTICAL OR HORIZONTAL PIPE)

STAINLESS STEEL

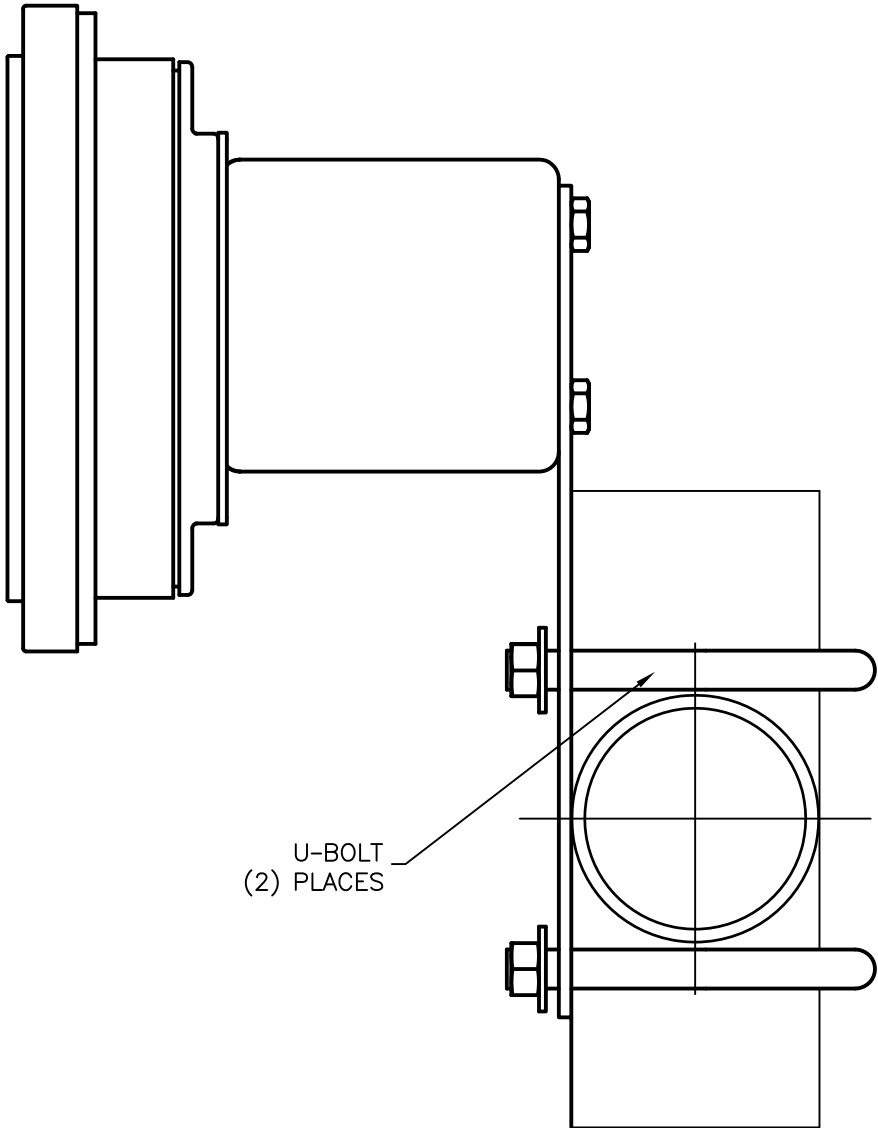
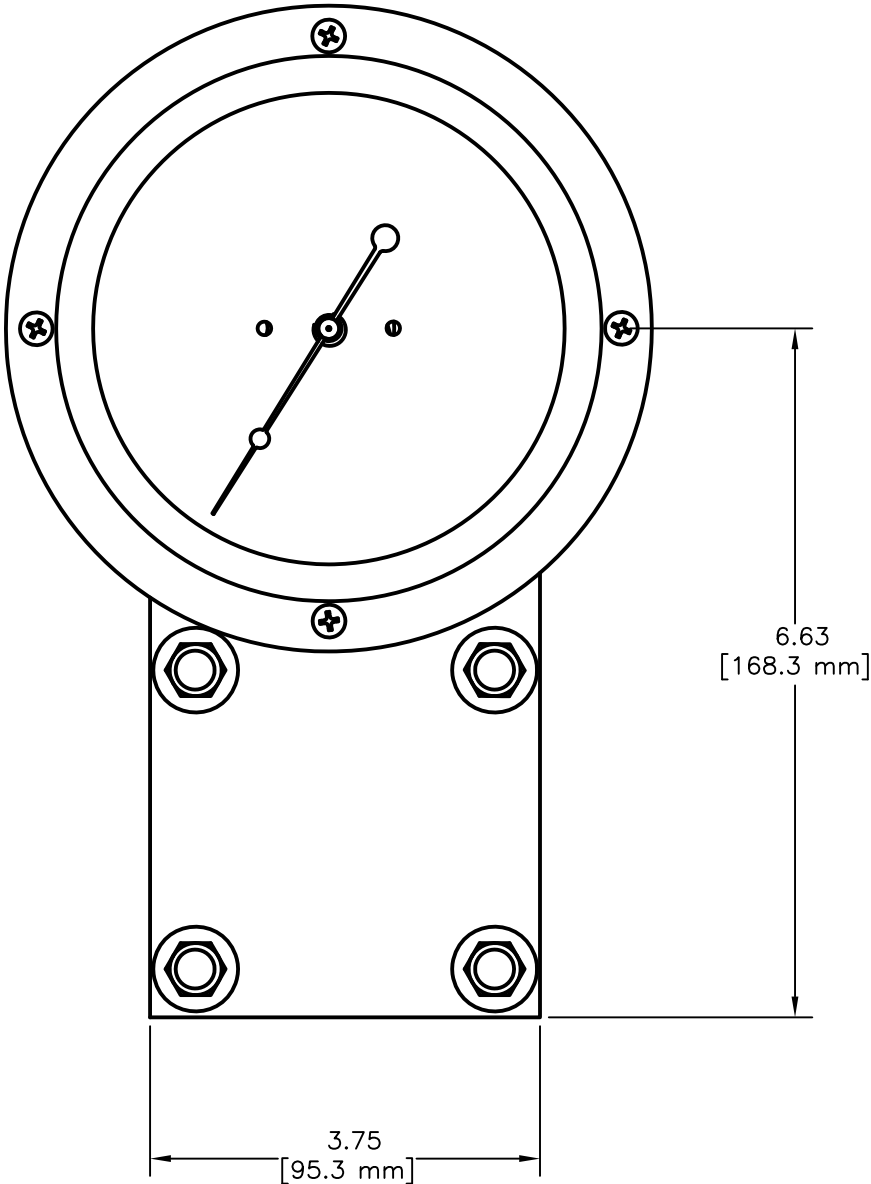

WALL MOUNT HOLE PATTERN

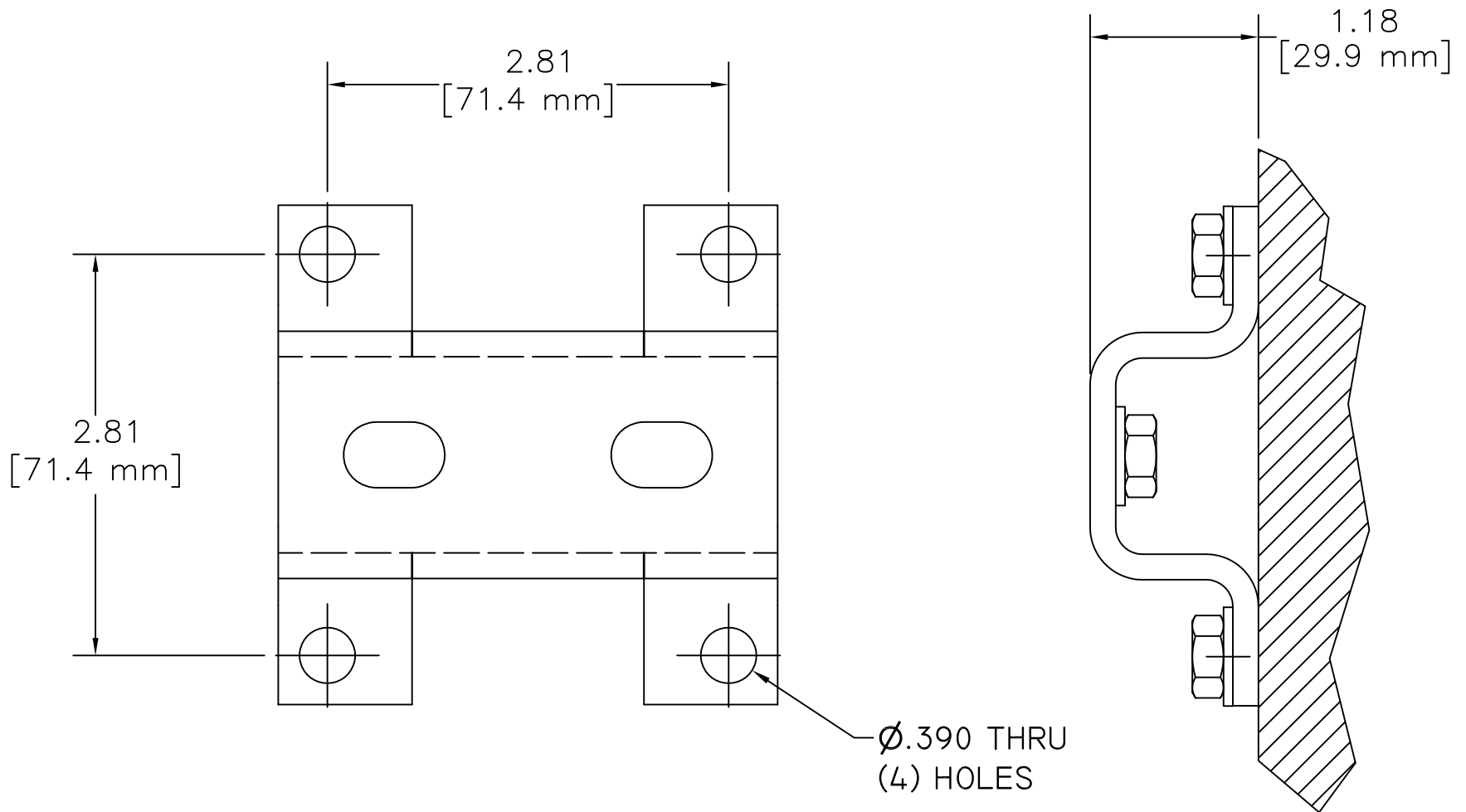

MODEL 105 and 106 PANEL CUT-OUT DIMENSIONS

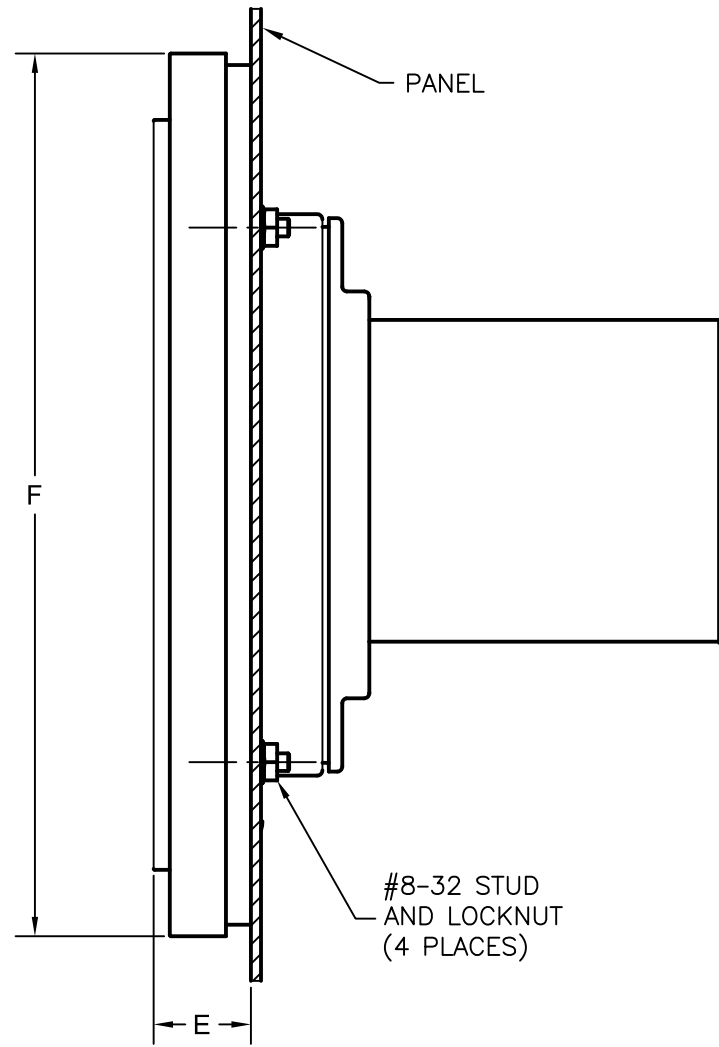
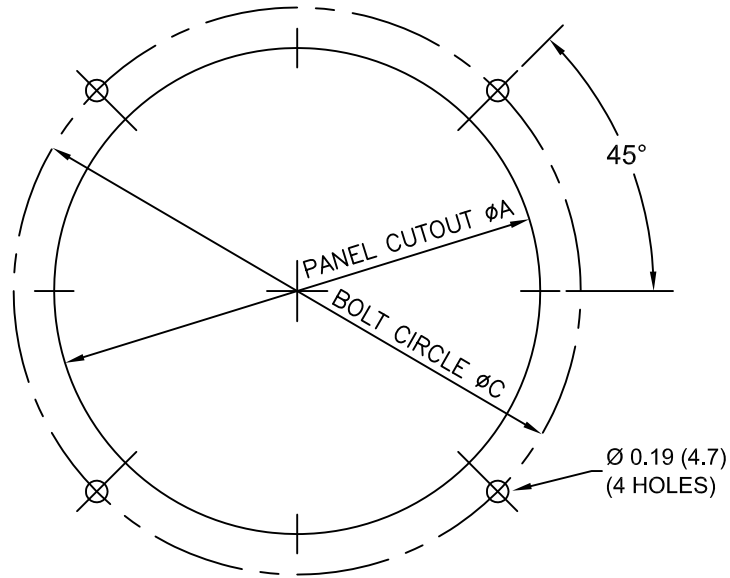

DIAL SIZE	DIAMETER A Inch (mm)	DIAMETER C Inch (mm)	LENGTH E Inch (mm)	DIAMETER F Inch (mm)
4-1/2 in.	5.30 (134.6)	5.63 (143.0)	0.85 (21.4)	6.21 (157.7)
6 in.	6.50 (165.1)	7.00 (177.8)	0.91 (23.1)	8.18 (208.0)

MODEL 105 AND 106 LLC PANEL CUT-OUT DIMENSIONS

