

MODEL 109 OVERALL DIMENISONS

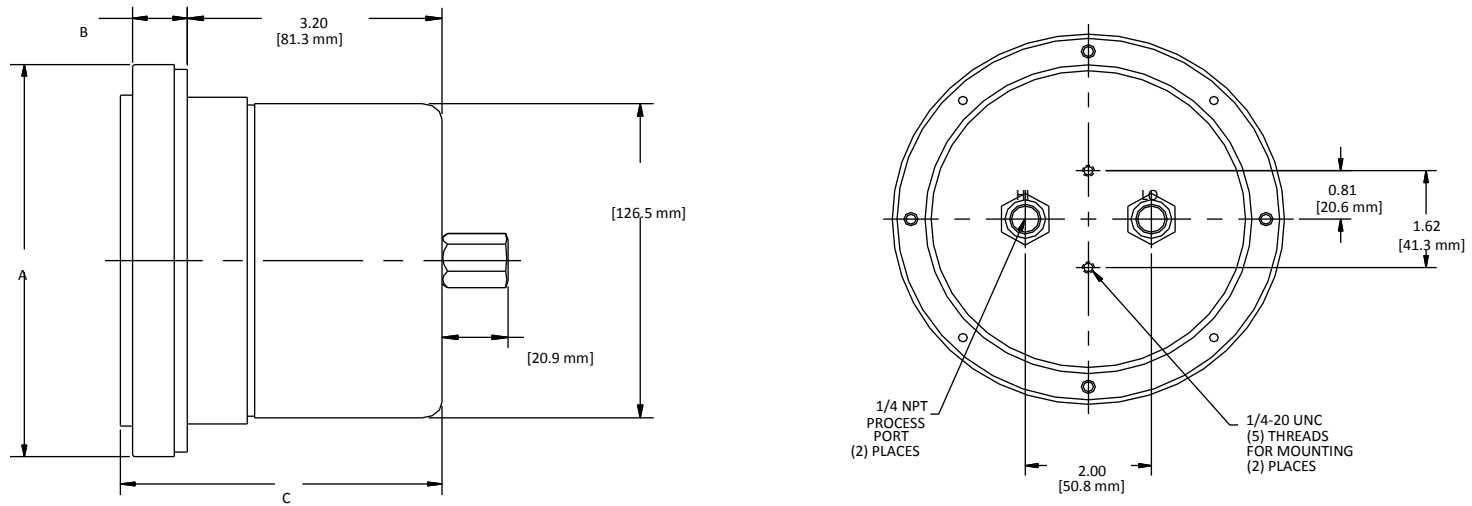

DIAL SIZE	DIAMETER A	LENGTH B	LENGTH C
	Inch (mm)	Inch (mm)	Inch (mm)
4-1/2 in.	6.21 (157.7)	0.70 (17.6)	4.05 (102.9)
6 in.	8.18 (208.0)	0.76 (19.3)	4.11 (104.4)

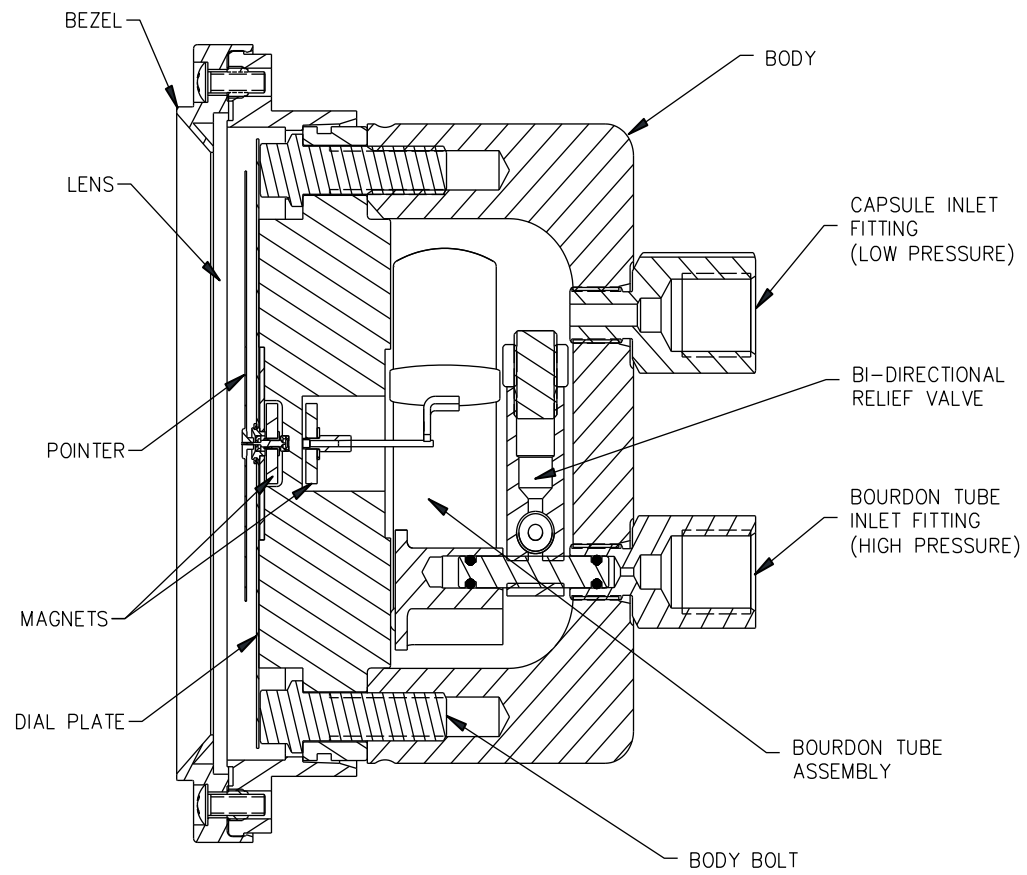

2 INCH PIPE MOUNT (FOR VERTICAL OR HORIZONTAL PIPE)

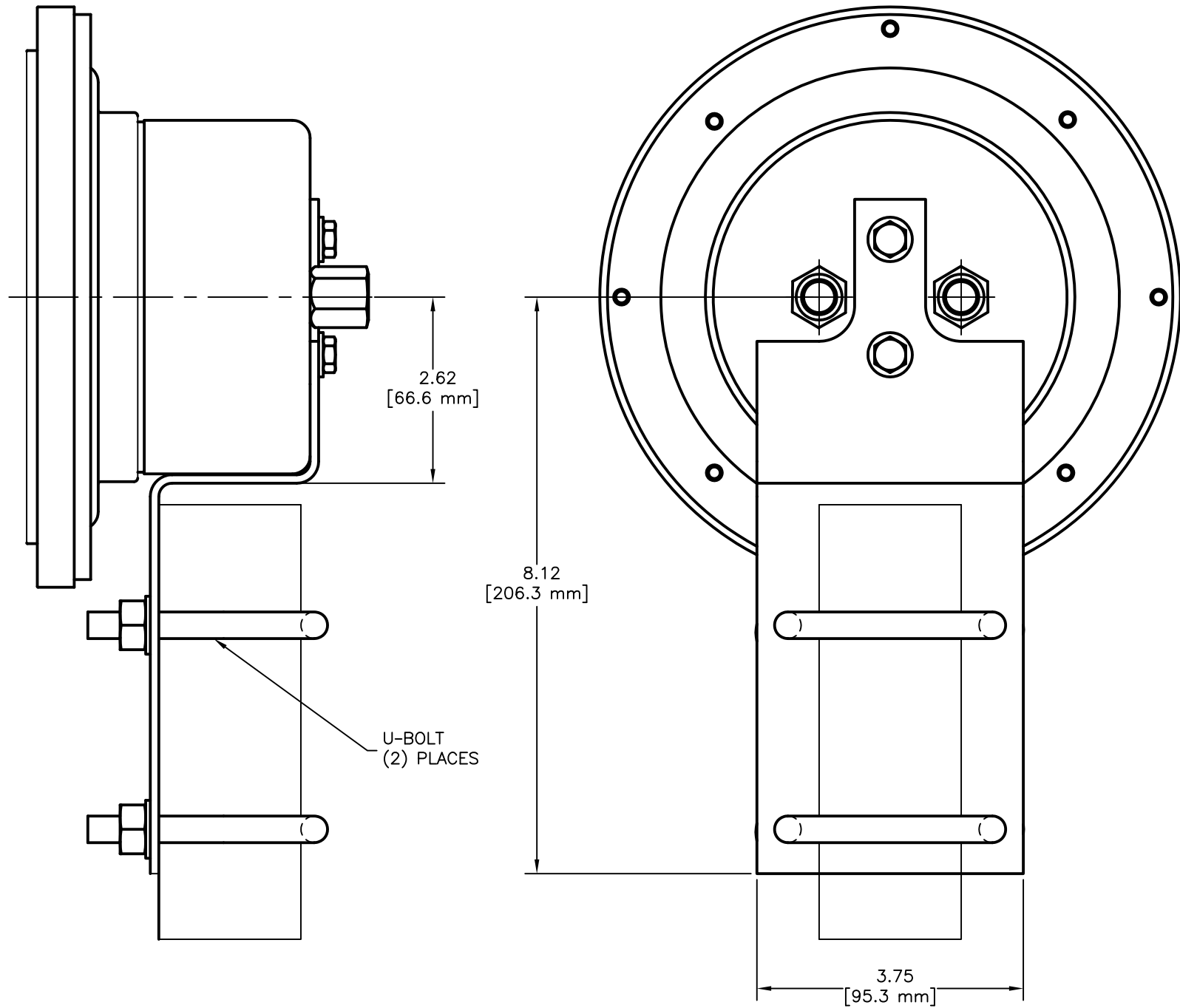

MODEL 109 WALL MOUNT

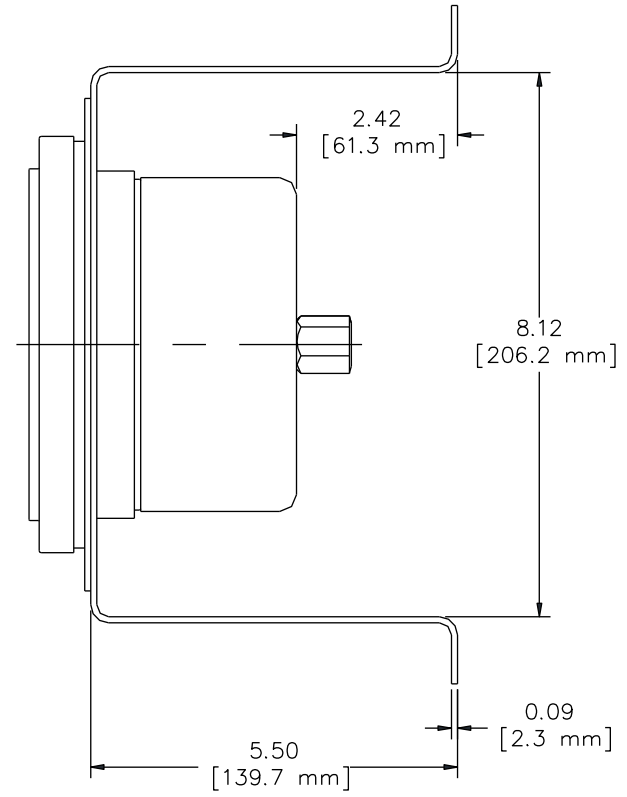
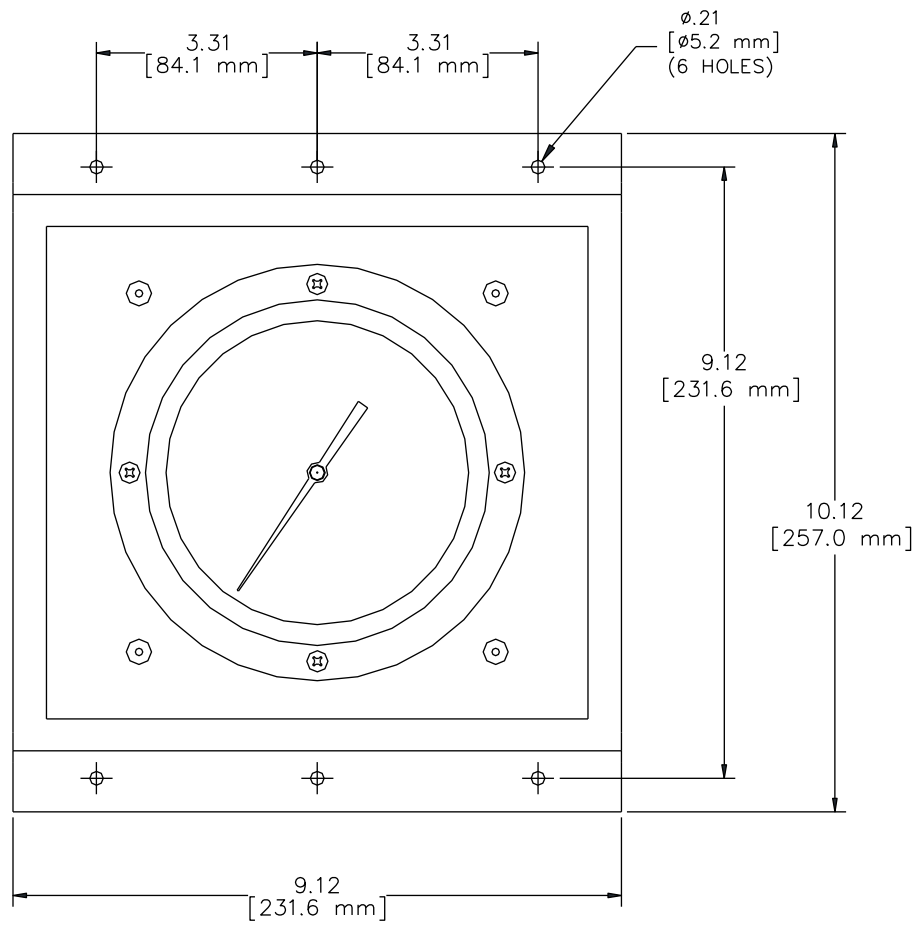

MODEL 109 PANEL CUT-OUT DIMENSIONS

DIAL SIZE	PANEL CUTOUT A Inch (mm)	BOLT CIRCLE C Inch (mm)
4-1/2 in.	5.30 (134.6)	5.63 (143.0)
6 in.	6.50 (165.1)	7.00 (177.8)

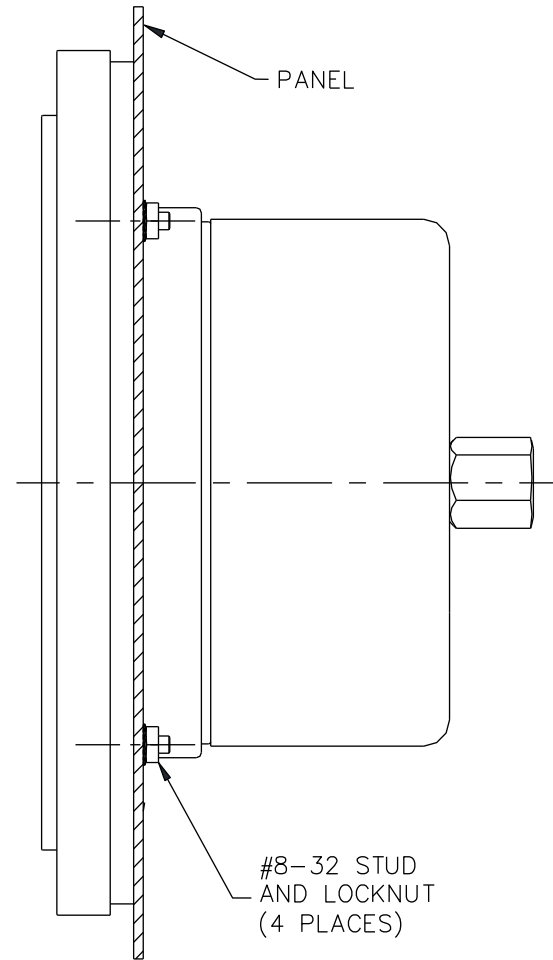
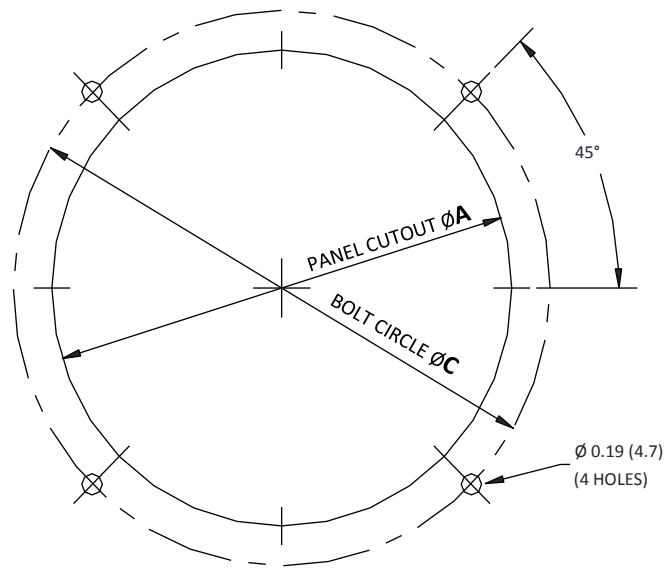

MODEL 105 AND 106 LLC PANEL CUT-OUT DIMENSIONS

