

# MODEL 123 WITH 1/2 NPT END CONNECTIONS

DIAL SIZE	DIMENSION L
	Inch (mm)
2-1/2 in.	5.73 (145.4)
4-1/2 in.	7.17 (182.0)
6 in.	7.73 (196.3)

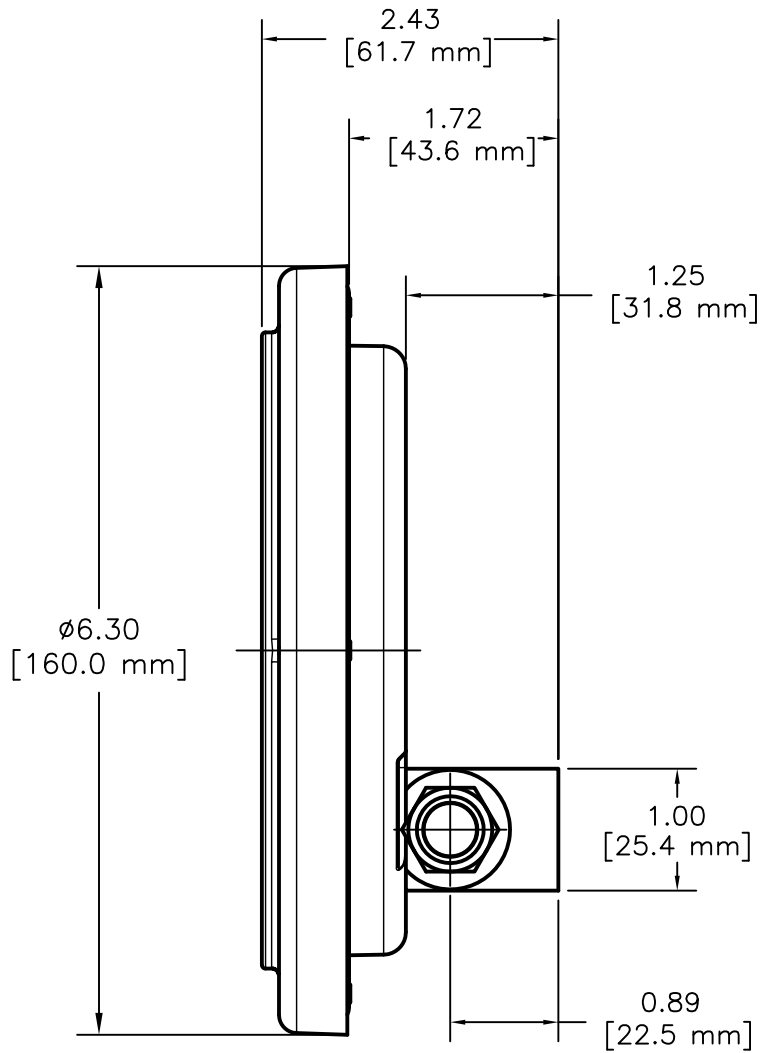

4-1/2 in. DIAL SHOWN

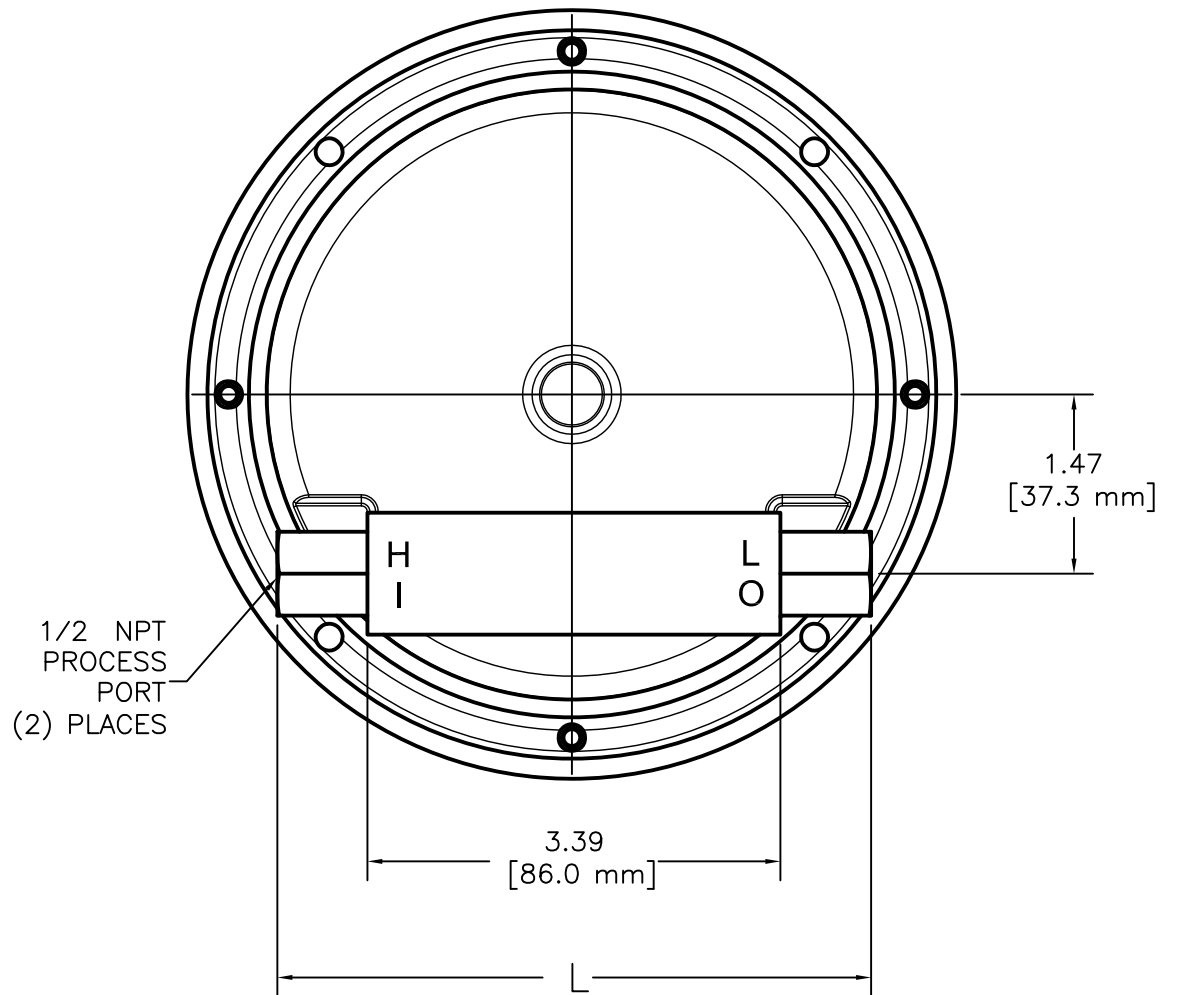

# MODEL 123 WITH 1/4 NPT END CONNECTIONS

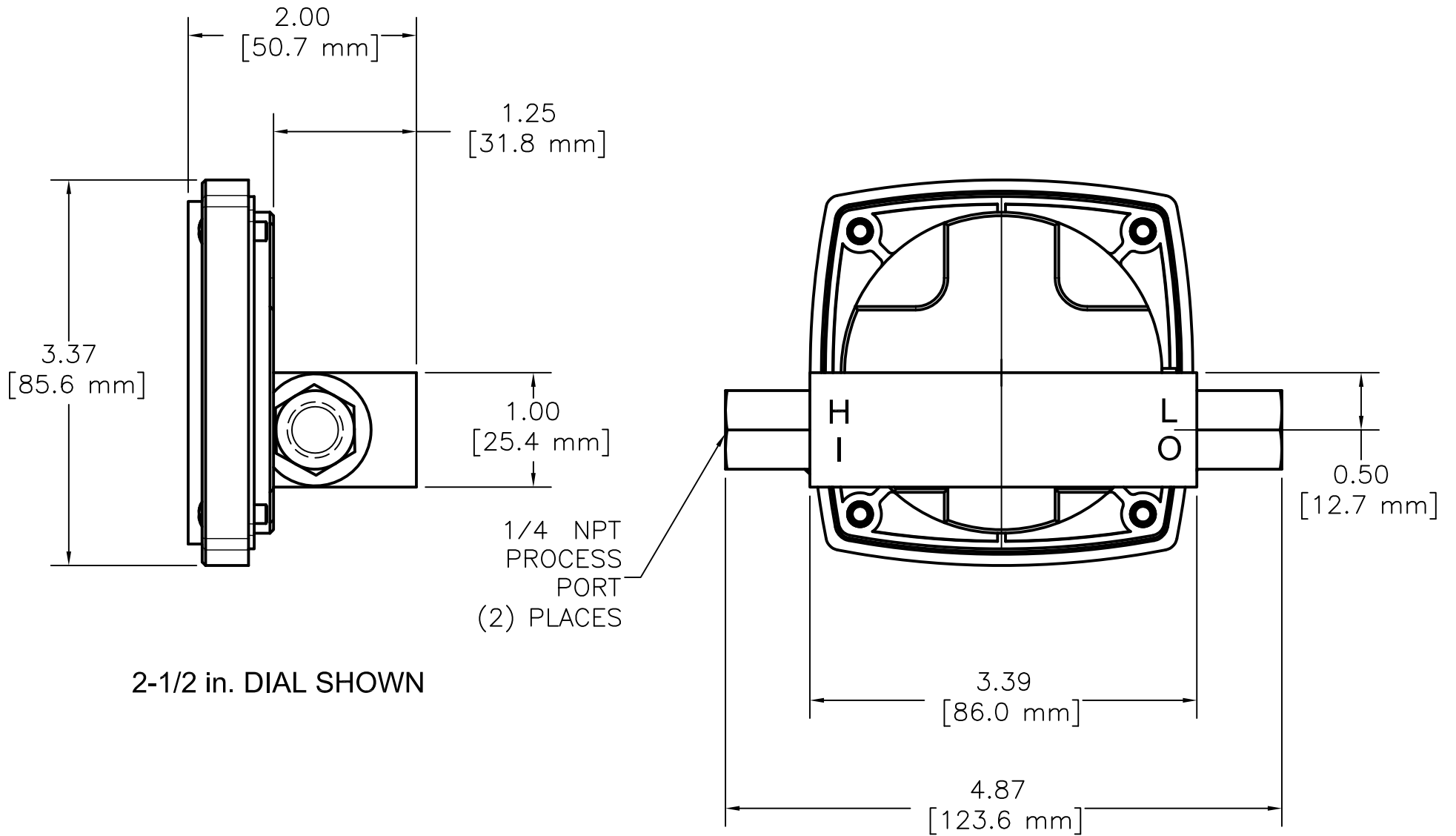

# 1/4-20 UNC BACK MOUNTING HOLES

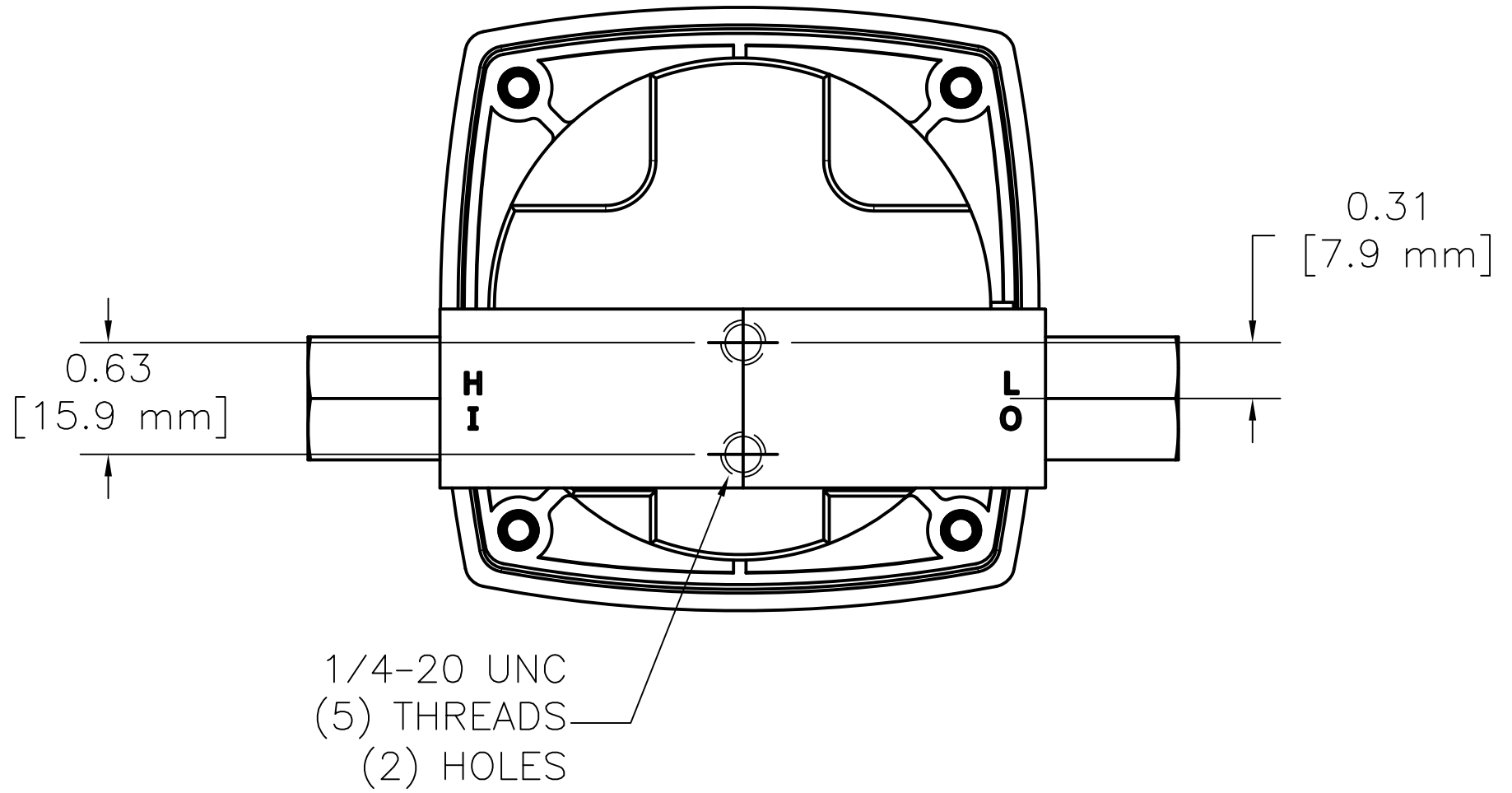

WALL MOUNT BRACKET (END CONNECTED PORTS)

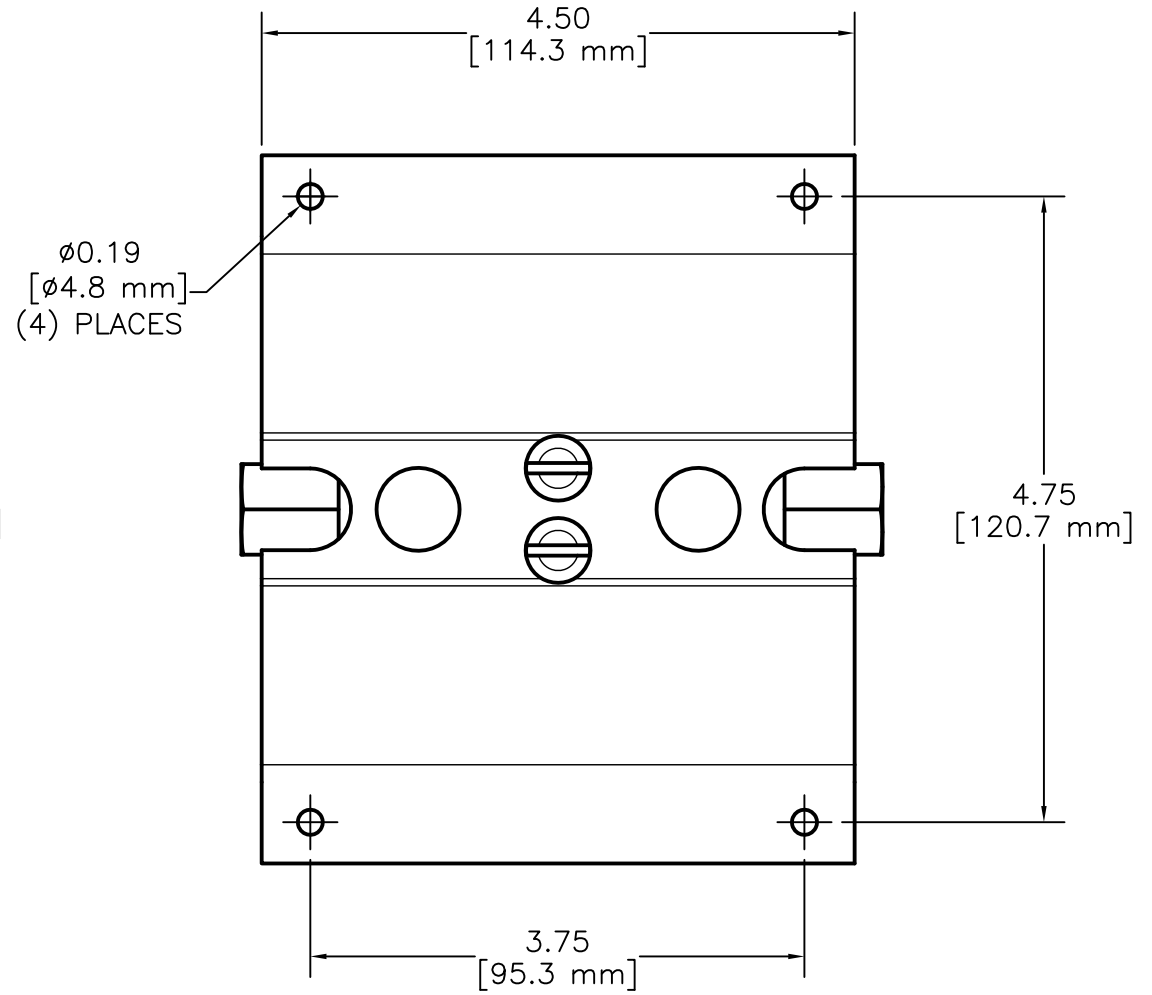
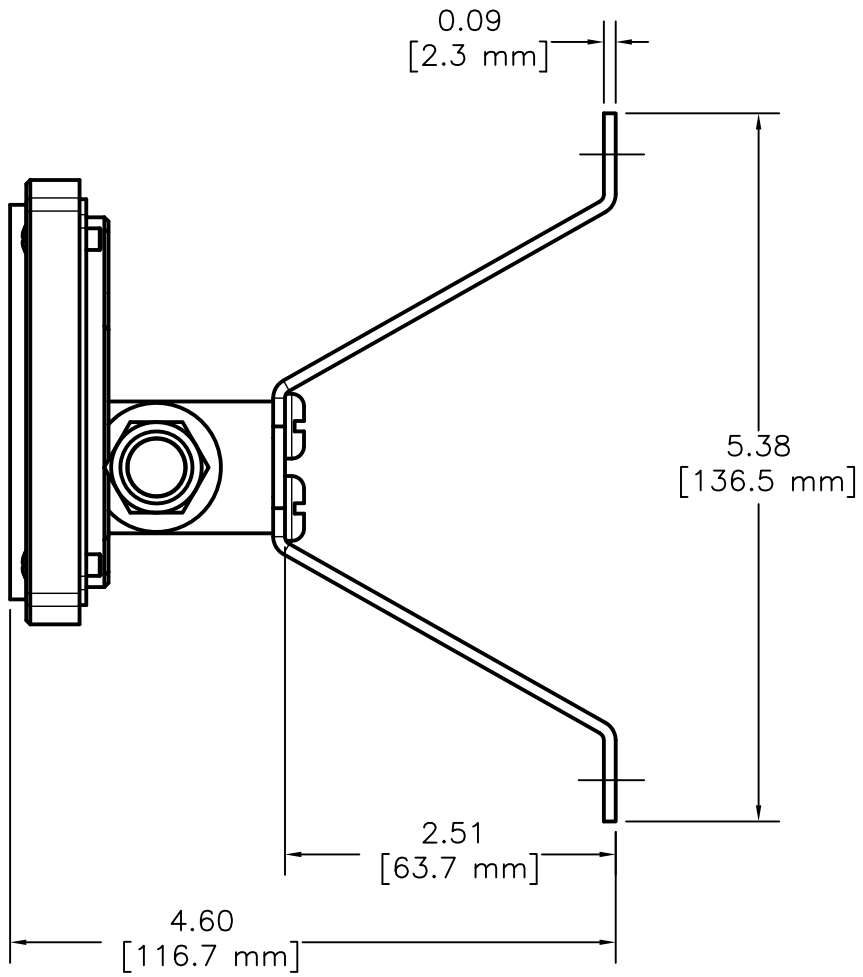

# MODEL 123 PANEL CUT-OUT DIMENSIONS

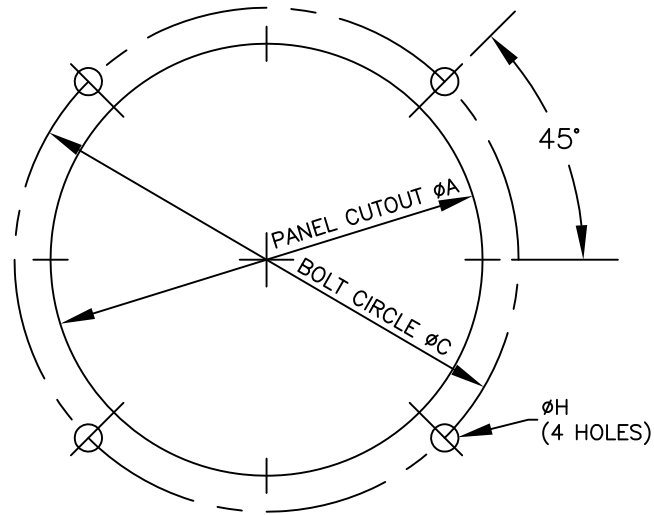

DIAL SIZE	DIAMETER A Inch (mm)	DIAMETER C Inch (mm)	DIAMETER H Inch (mm)
2-1/2 in.	3.00 (76.2)	3.50 (88.9)	0.19 (4.7)
4-1/2 in.	5.30 (134.6)	5.63 (143.0)	0.19 (4.7)
6 in.	6.50 (165.1)	7.00 (177.8)	0.19 (4.7)

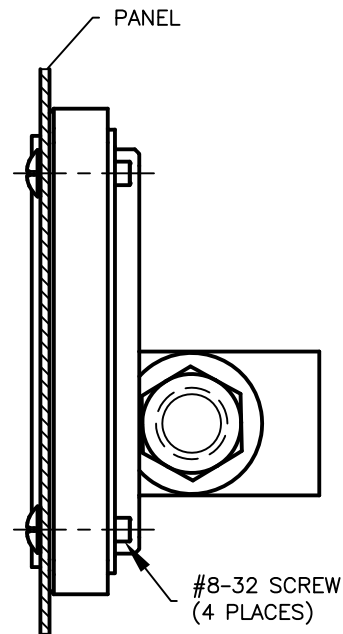

2-1/2 in. DIAL

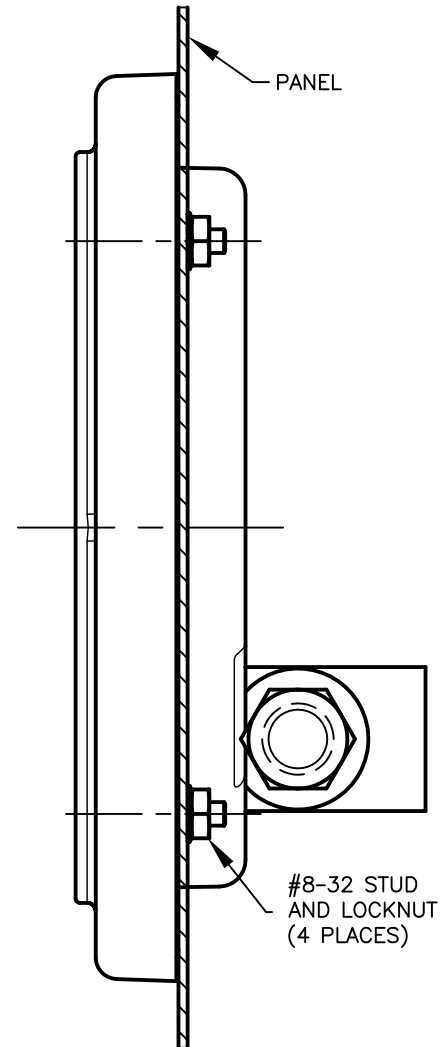

4-1/2 in. & 6 in. DIALS