

BACK CONNECTED PROCESS PORTS

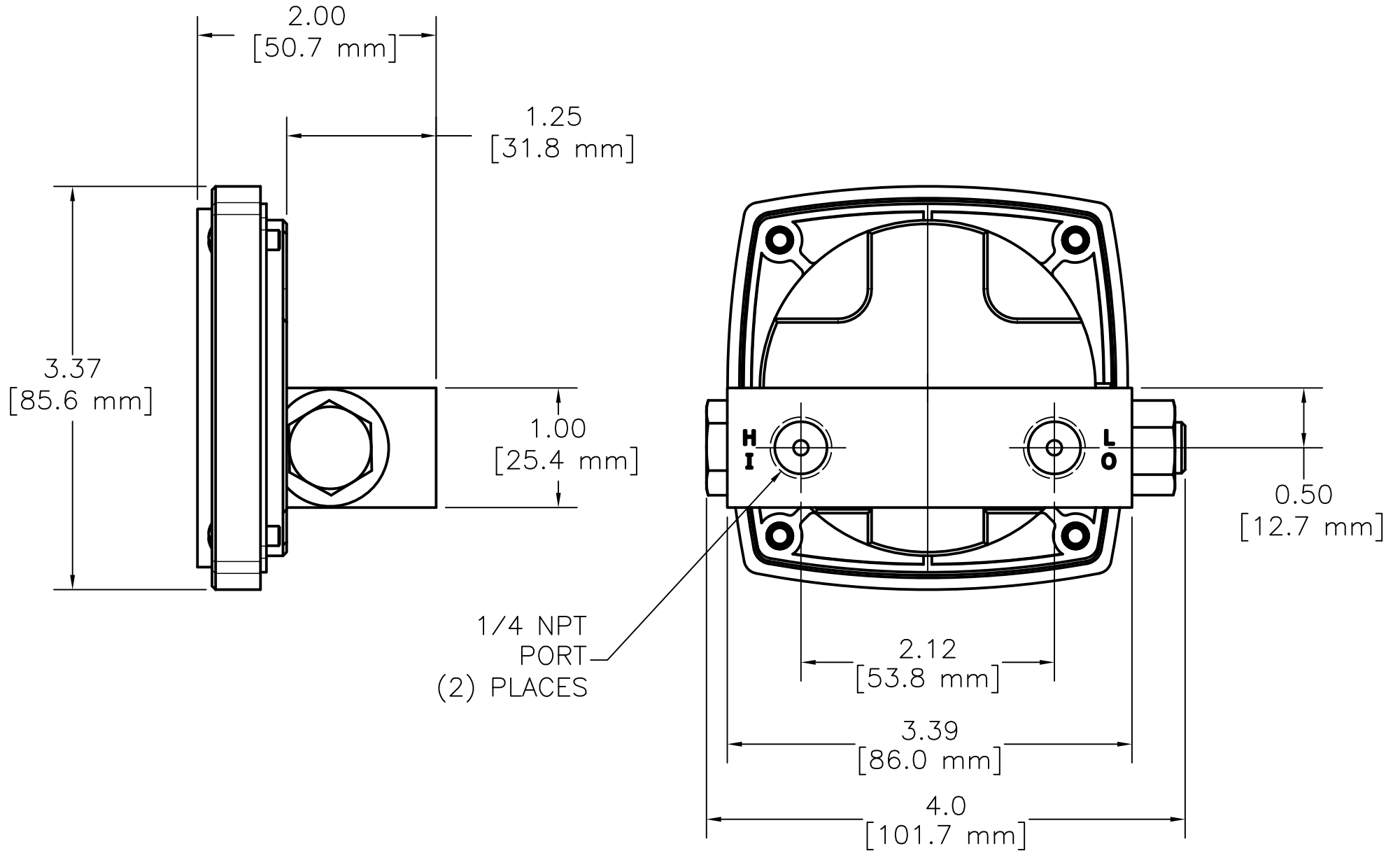

END CONNECTED PROCESS PORTS

DIAL SIZE	END PORT PIPE THREAD	DIMENSION L Inch (mm)
2-1/2 in, 3-1/2 in, 4-1/2 in, 6 in.	1/4 NPT	4.87 (123.6)
2-1/2 in.	1/2 NPT	5.73 (145.4)
3-1/2 in.	1/2 NPT	6.53 (165.7)
4-1/2 in.	1/2 NPT	7.17 (182.0)
6 in.	1/2 NPT	7.73 (196.3)

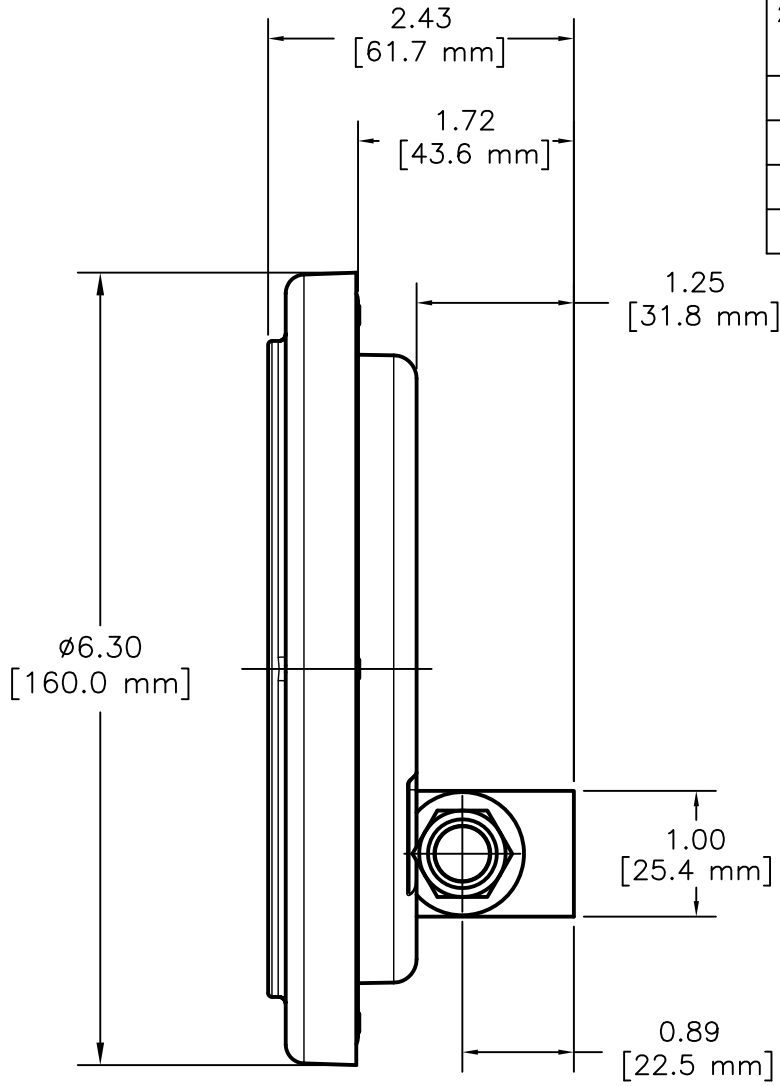

4-1/2 in. DIAL SHOWN

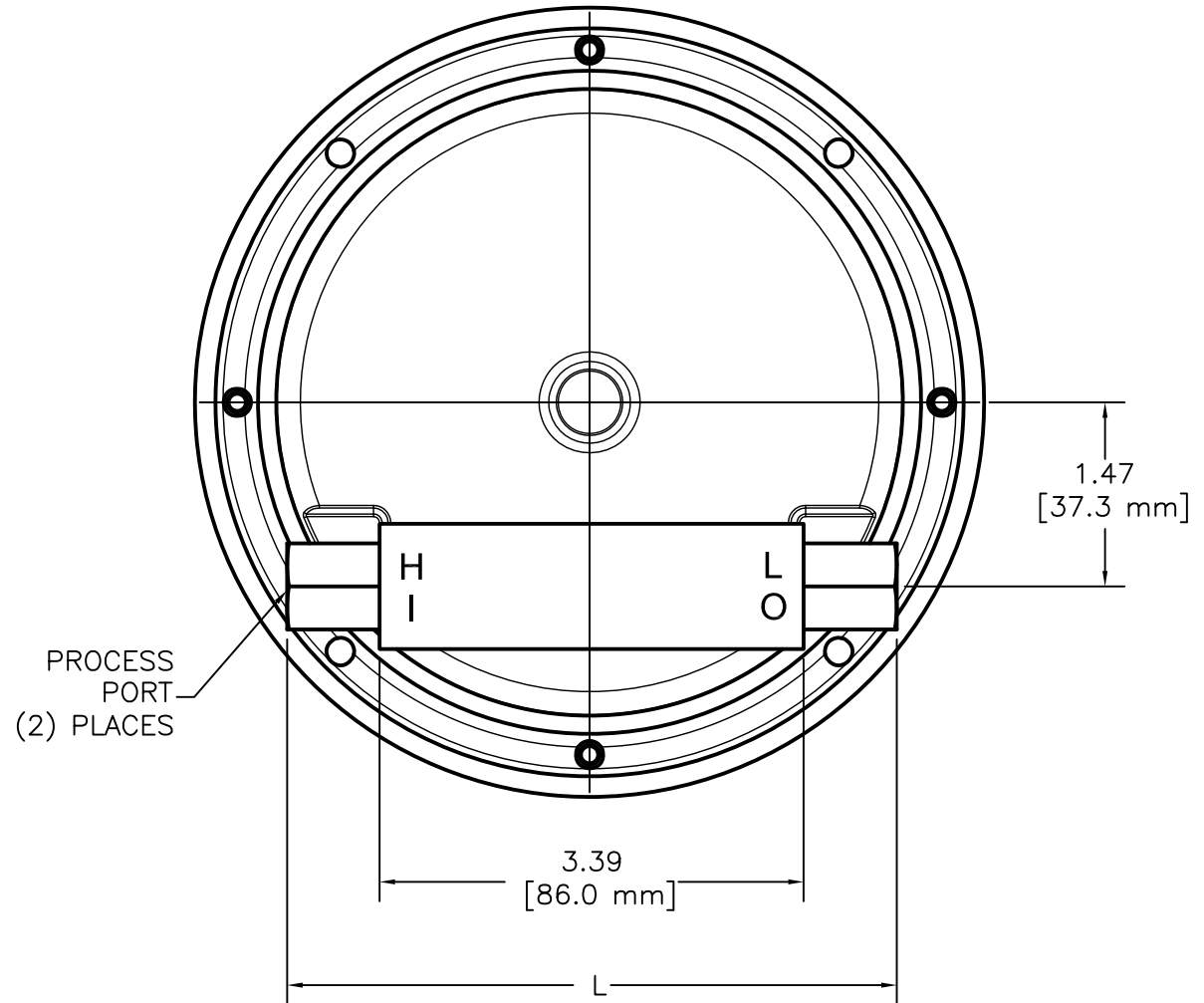

MODEL 124 END CONNECTED WITH ELECTRICAL
(4-1/2 INCH DIAL SHOWN)

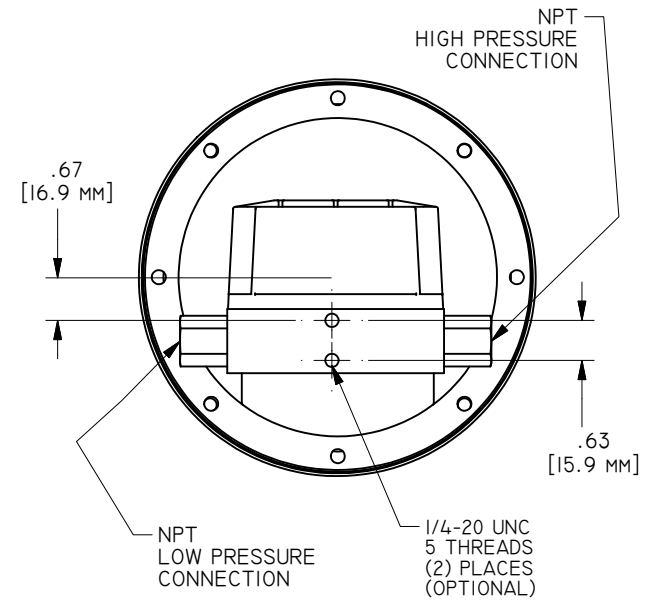
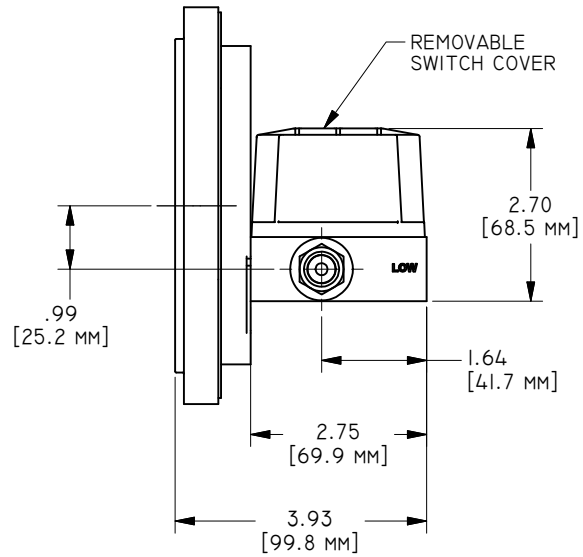
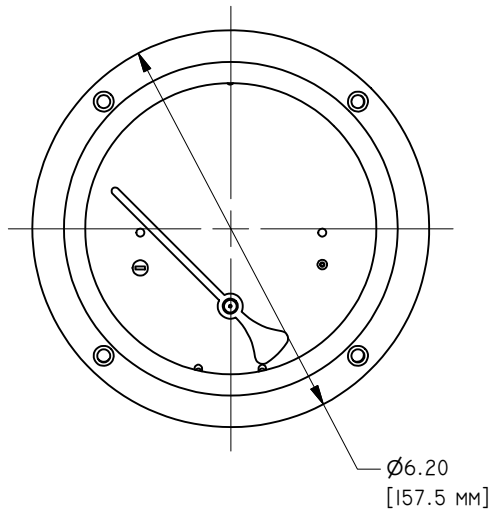

DIAL SIZE	END PORT PIPE THREAD	DIMENSION L Inch (mm)
2-1/2 in, 3-1/2 in, 4-1/2 in, 6 in.	1/4 NPT	4.87 (123.6)
2-1/2 in, 3-1/2 in, 4-1/2 in, 6 in.	1/2 NPT	5.73 (145.4)

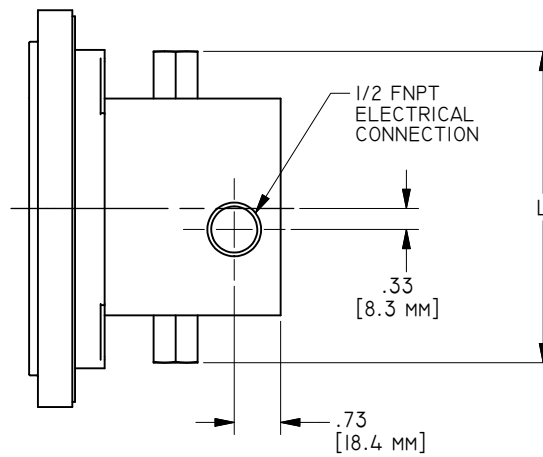

MODEL 124 BACK PORTS WITH ELECTRICAL
(2-1/2 INCH DIAL SHOWN)

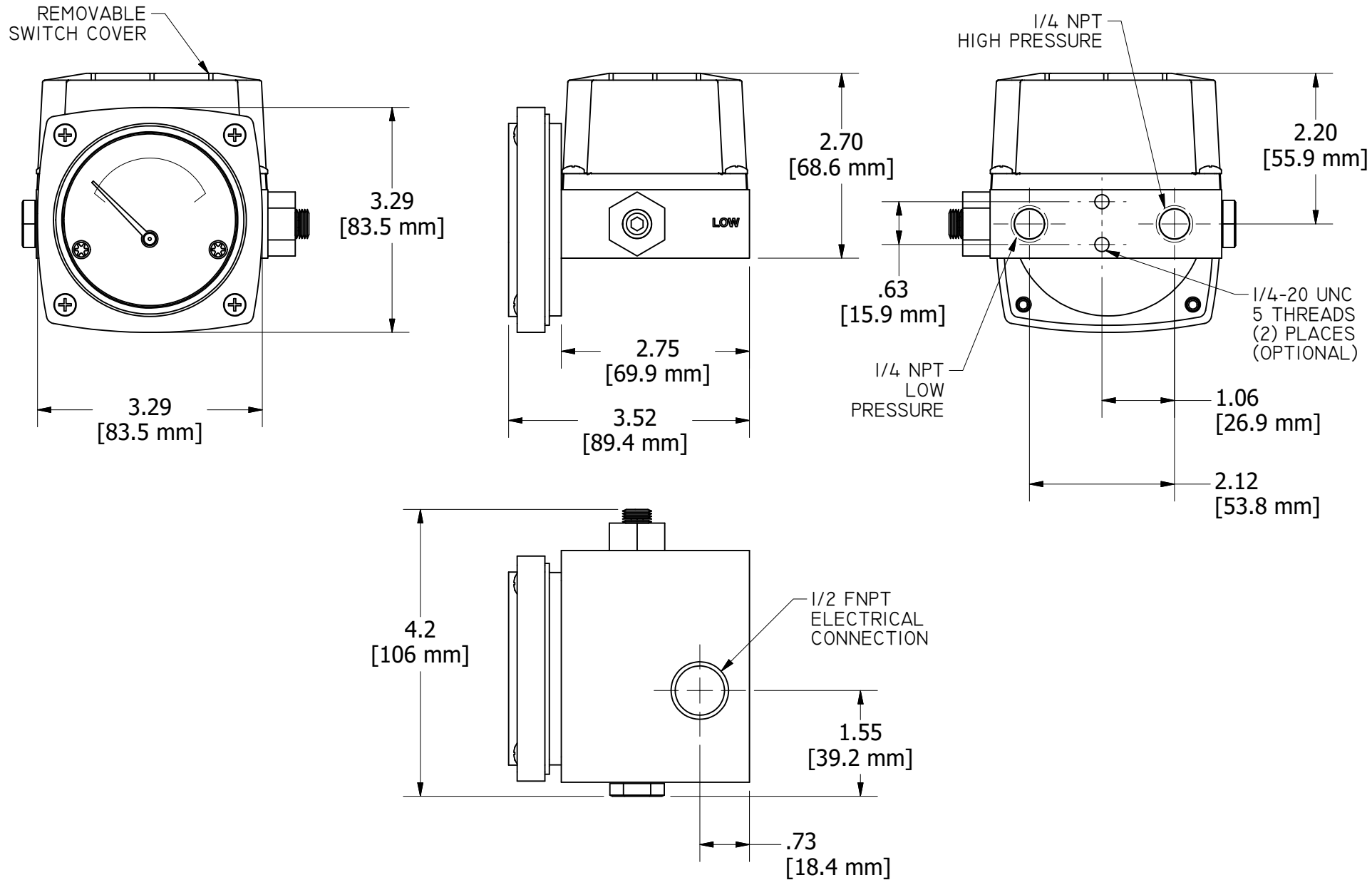

1/4-20 UNC BACK MOUNTING HOLES

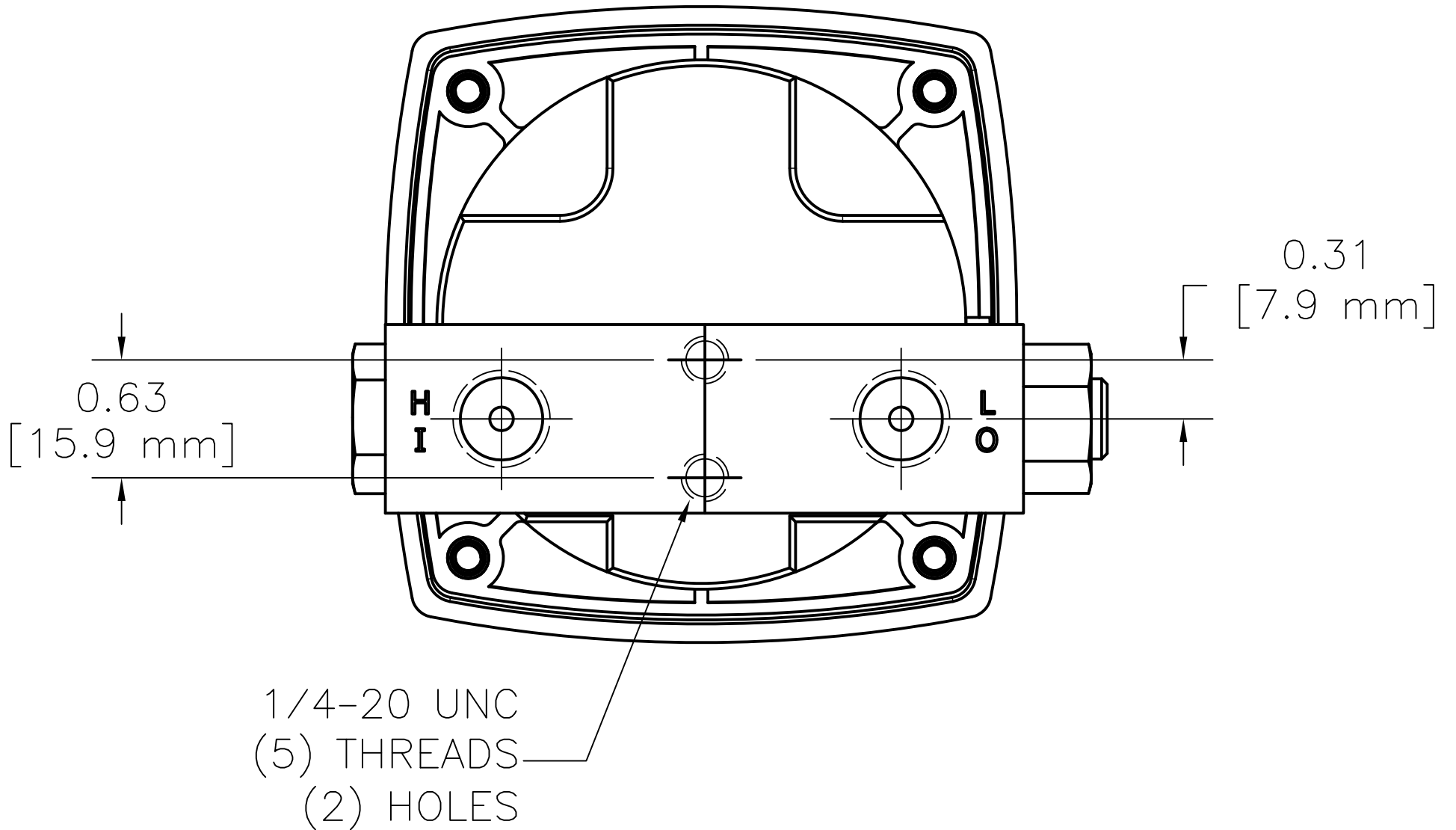

2 INCH PIPE MOUNT (FOR VERTICAL OR HORIZONTAL PIPE)

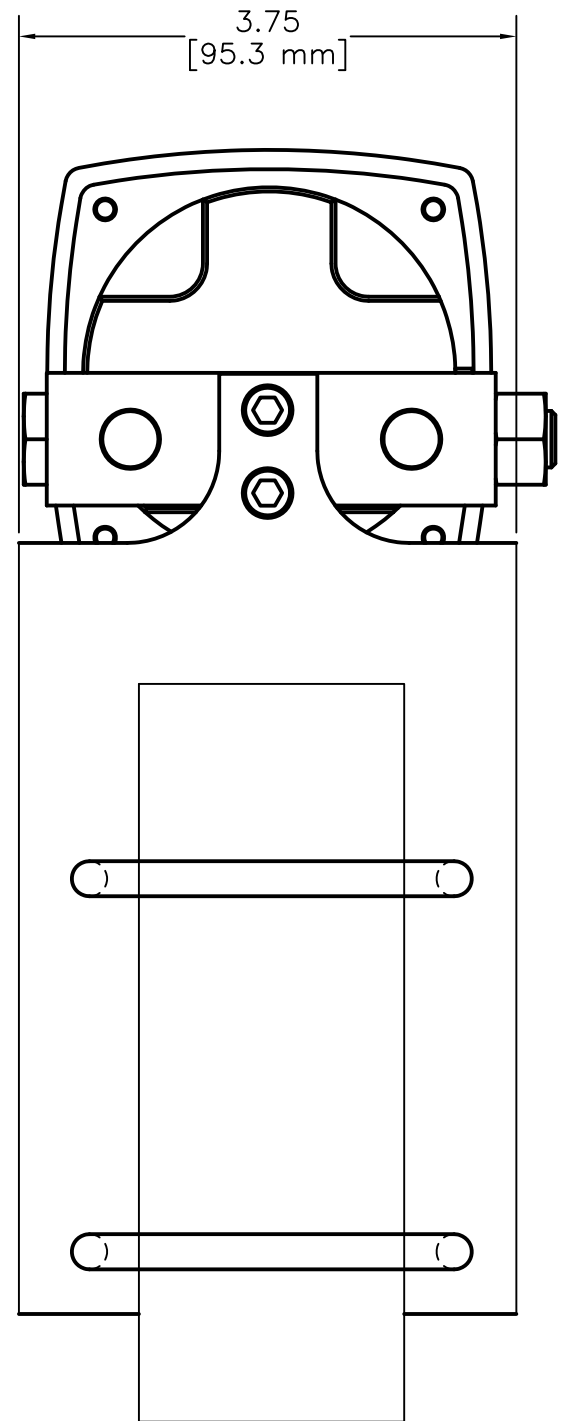
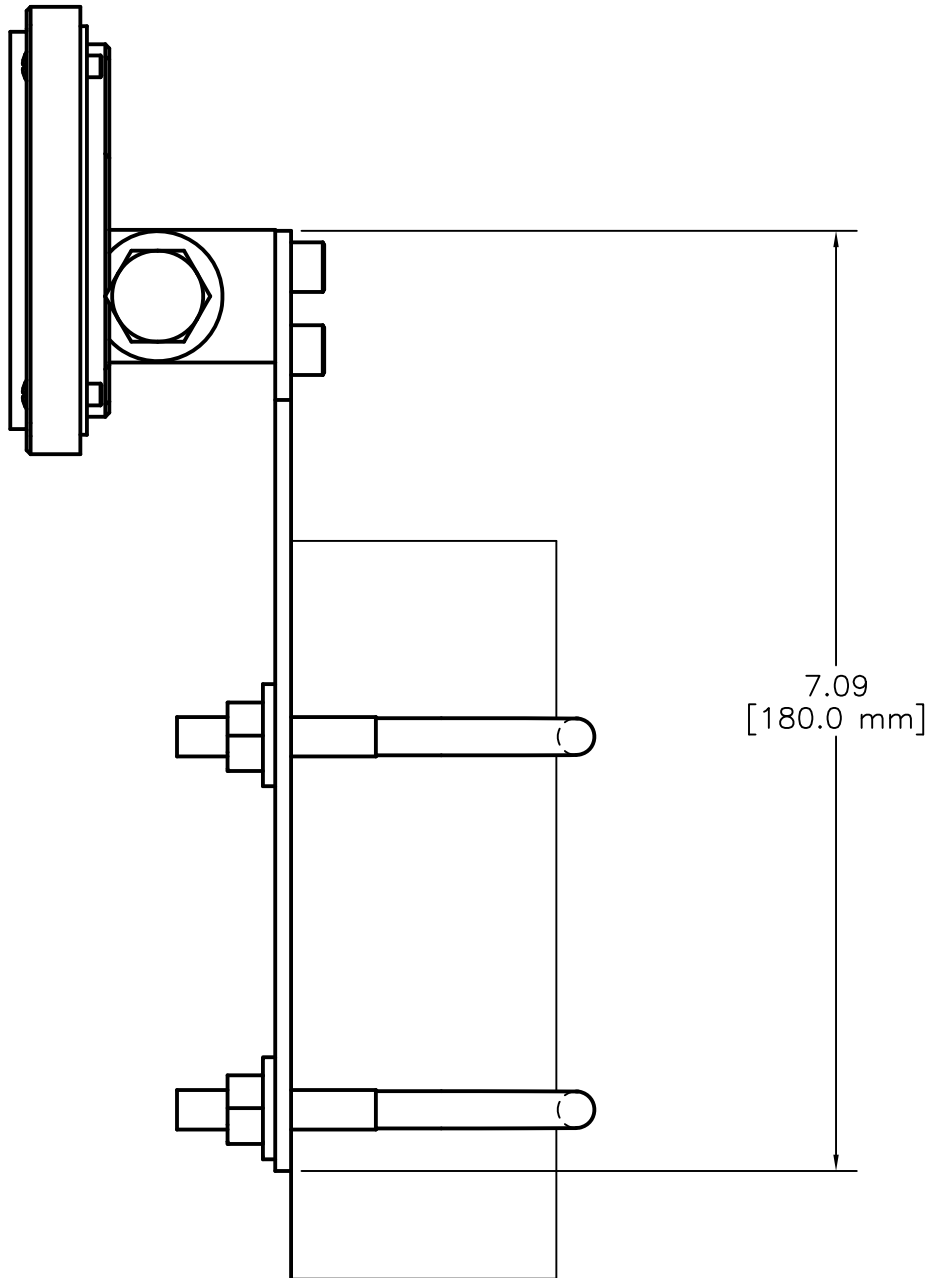

MODEL 124 ELECTRICAL WITH PIPE MOUNT
(4-1/2 ALUMINUM FRONT SHOWN)

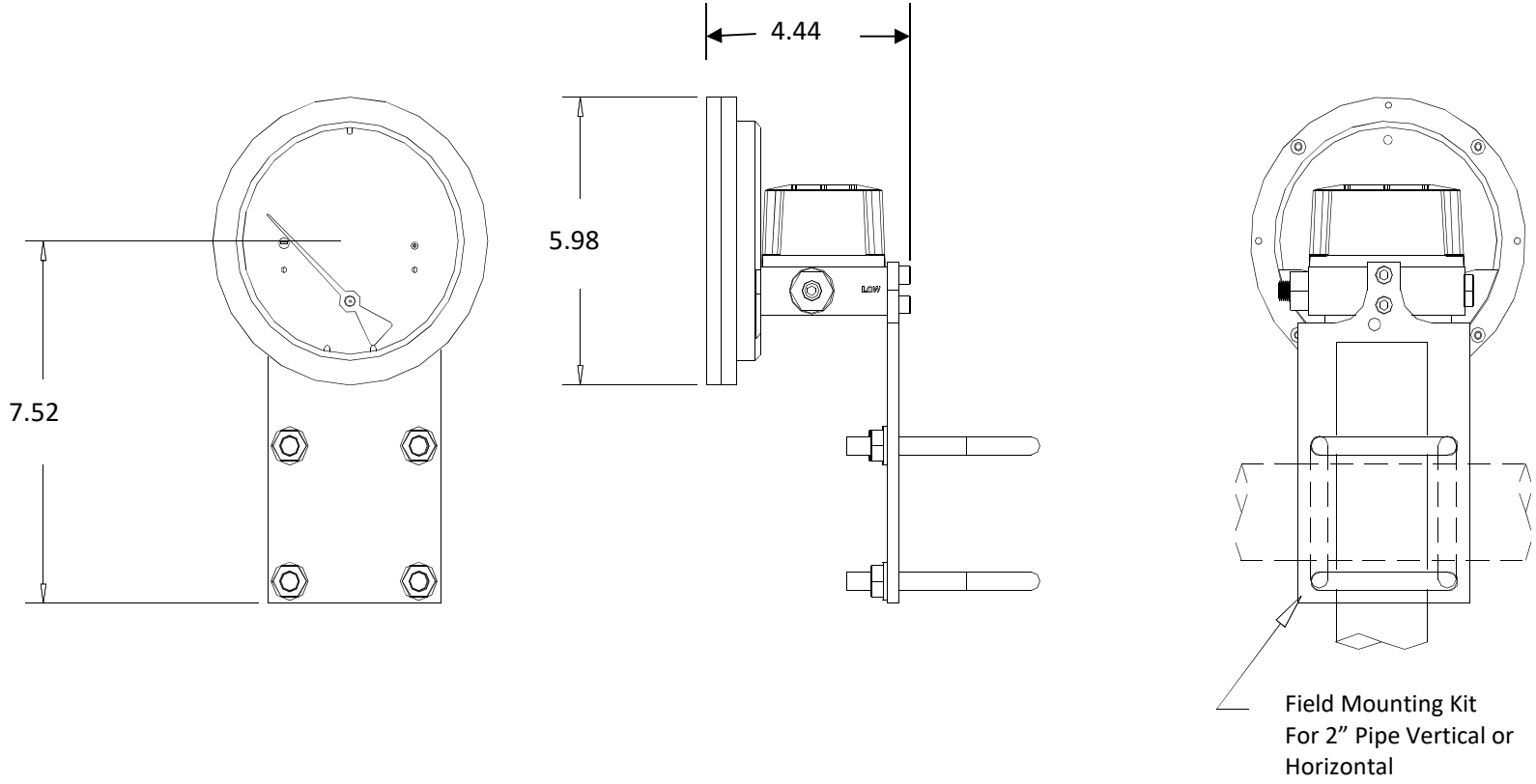

WALL MOUNT BRACKET (END CONNECTED PORTS)

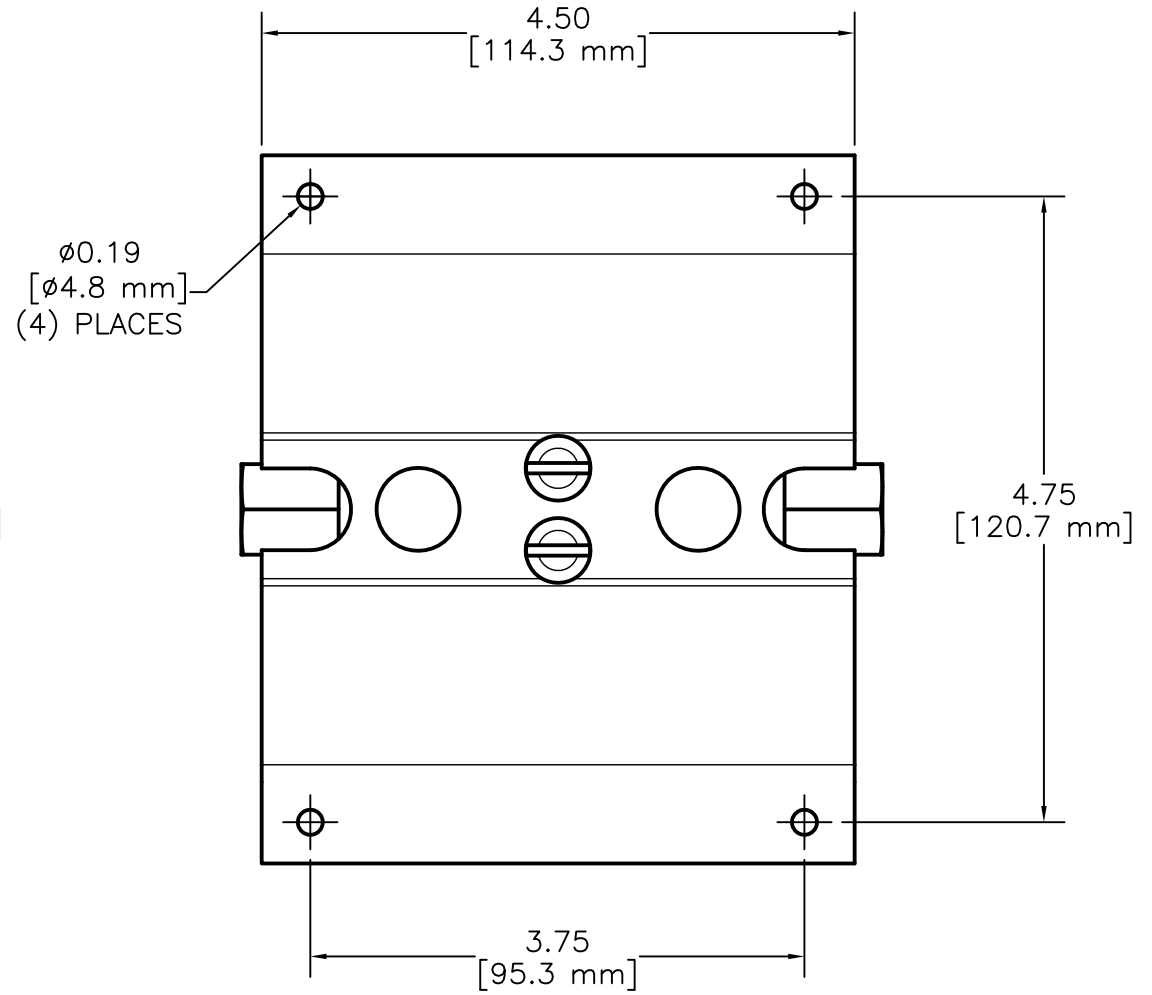
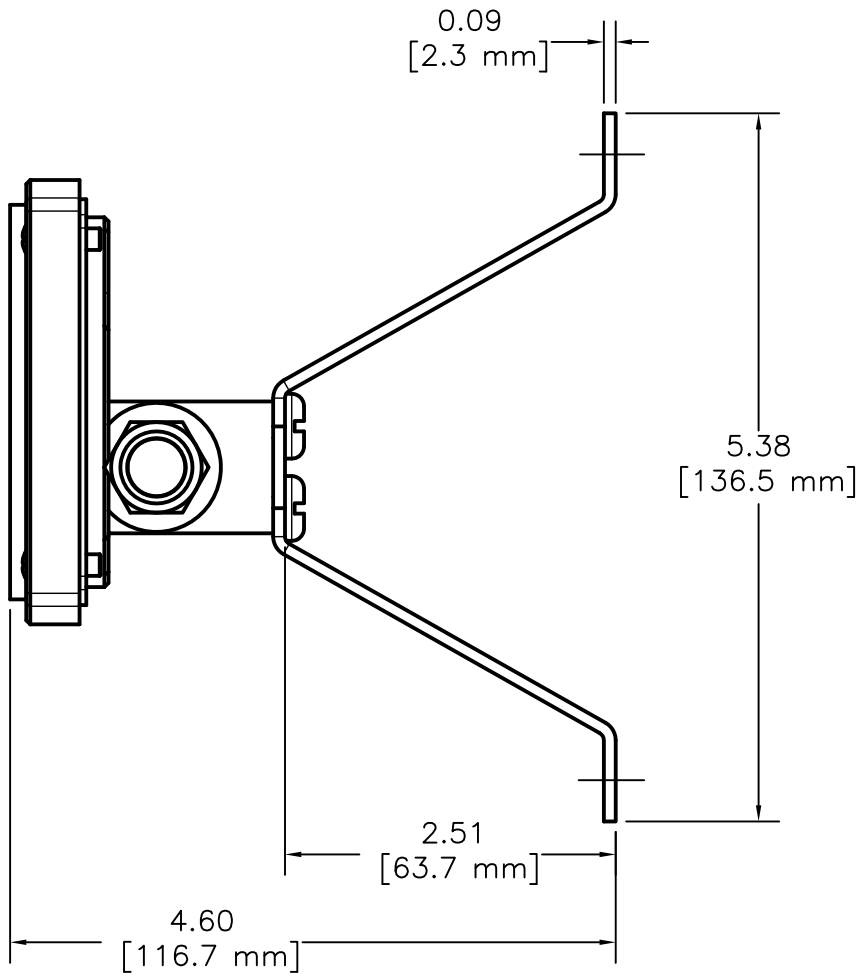

MODEL 124 WALL MOUNT WITH ELECTRICAL

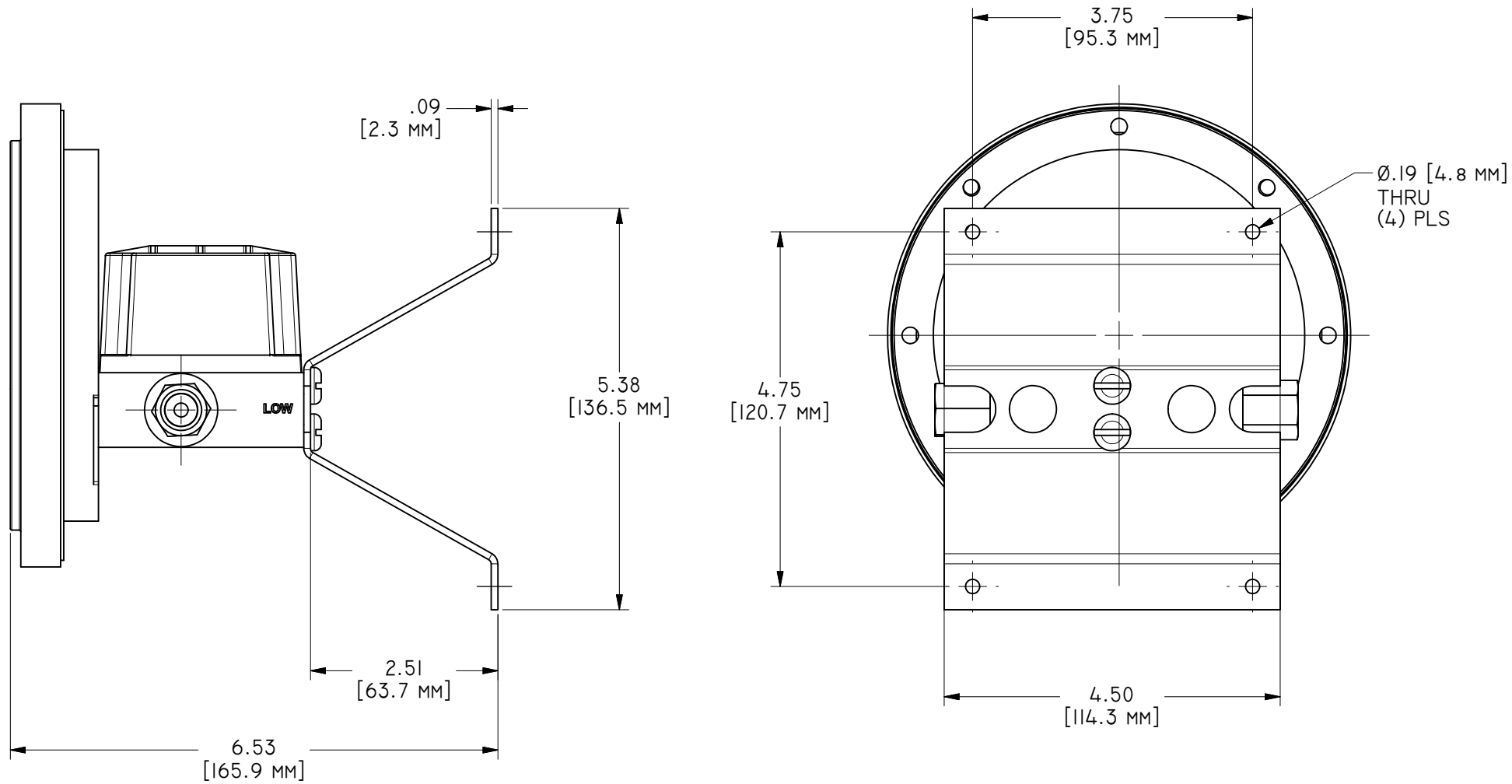

MODEL 124 PANEL CUT-OUT DIMENSIONS

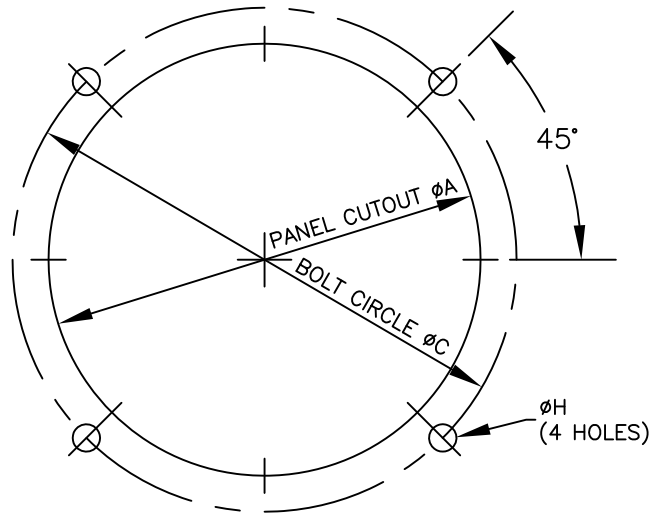

DIAL SIZE	DIAMETER A Inch (mm)	DIAMETER C Inch (mm)	DIAMETER H Inch (mm)
2-1/2 in.	3.00 (76.2)	3.50 (88.9)	0.19 (4.7)
4-1/2 in.	5.30 (134.6)	5.63 (143.0)	0.19 (4.7)
6 in.	6.50 (165.1)	7.00 (177.8)	0.19 (4.7)

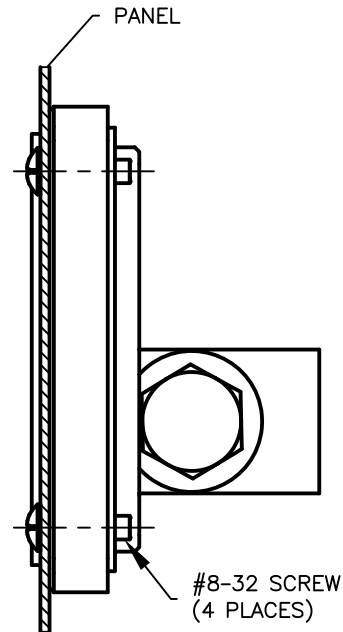

2-1/2 in. DIAL

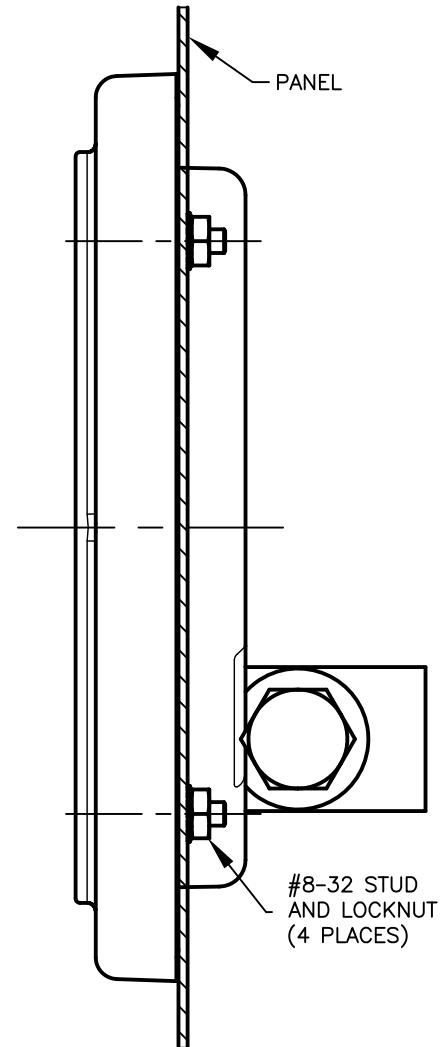

4-1/2 in. & 6 in. DIALS