

Electrical Installation and Operating Instructions - Model 522 / 522C

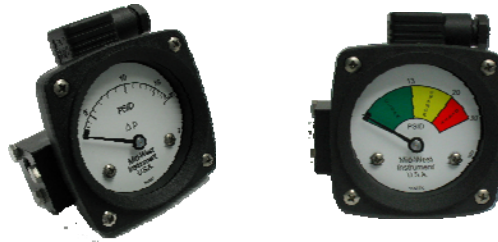

1. Safety



Before installing verify compatibility to the process media and temperature in contact with the wetted parts. Incompatible media and / or operation at temperature extremes can cause premature degradation of materials which could result in safety risk to personnel.

Verify the selected pressure range (differential pressure and working pressure) and the switch ratings are within specification for your application.

Perform all electrical adjustments with power removed.

The Model 522 product utilizes a diaphragm design which isolates the high process from the low process. For over pressure conditions (Hi over Lo) the assembly is limited to a maximum differential pressure of 200 PSID . Reverse pressure (Lo over Hi) conditions are not recommended.



Warning! *Remaining media may result in a risk to personnel, environment etc. Use sufficient precautionary measures when removing and transporting the product.*

Warning! *If installing product within another enclosure that is pressure tight, please verify all process connection are leak tight. Leakage within a pressure tight (ie NEMA 4X) enclosure could cause a pressure buildup within the enclosure and cause a burst scenario.*

1.1 Intended use: The indicating / non-indicating differential pressure switches are used for monitoring differential pressures in industrial applications. The manufacturer shall not be liable for any claims if the product is used in applications contrary to the intended use.

1.2 Personnel: Personnel installing and putting this instrumentation into service shall be suitably trained and qualified in accordance with local codes, practices and regulations.

1.3 Labeling / Marking: This product bears this mark and complies with the relevant European Directives identified on the declaration of conformity:



Equipment protected throughout by double insulation.



Caution Risk of Danger. Please refer to this documentation when seen marked on the product.



This product is CE marked for conformance with the Low Voltage Directive (2006/95/EC) and RoHS Directive 2011/65/EU.

Electrical Installation and Operating Instructions - Model 522/522C

2.0 General Specifications

Non-electrical:

Parameter	Limits
Working Pressure(PSI)	1000 (AL) (SS) 500(Acetal)
Proof Pressure(PSI)	2,000 (AL) (SS) 1000 (Acetal)
Temperature	-40° to 200° F
Differential Pressure Range (PSID)	5 PSID Min. 50 PSID Max.
Indicator Accuracy ASME B40.100	+/- 5% FSR
DP Over-Range	+ 200 PSID **

Electrical:

Parameter	Switch	
Electrical Specification	A	E
Function	SPDT	SPST Normally Open
*Power	3 W	60 W
Max. Current	0.25 Amps	3.0 Amps
Max. Voltage VAC/VDC	120	240
Adjustability(FSR)	25% - 75%	40% - 95%
Interface	DIN 43650/ ISO 4400 Connector	

- * Product of the switching voltage and current shall not exceed the power rating of the device.
- ** Operation with negative pressure is not recommended.

3.0 Product Description: Differential pressure is sensed by a flexible elastomer diaphragm and a calibrated spring.. The magnetically coupled gauge pointer located outside the pressure housing follows the movement of the piston magnet and indicates differential pressure on the dial. The switch is also magnetically operated and is located outside of the pressure housing. The switch is mechanically adjustable allowing the customer to set the switch within a defined adjustment span of the range of the instrument.

This instrument is suited for dissimilar fluids, wet gas, and fluids with particulates present..

4.0 Installation:

Mechanical Connections: 1/4" FNPT end connections are provided. There are 2 connections identified on the gauge body as "Hi" and "Lo" for High pressure and Low pressure respectively. Be sure these are plumbed properly in your system. Improper connection may cause damage or improper operation for a period of time.

Instrument Location: On liquid service the instrument should be mounted below the process connections to facilitate self-bleeding. On gas service it should be located above the process connections to promote self-draining. If the process contains particulates, a pigtail loop or drop leg (manometer "U-tube" configuration) in the tubing will minimize the possibility of it migrating into the instrument.

Temperature Limitations: For process temperatures higher than the rated temperature of the dp gauge / switch, use process tubing to reduce the temperature. A general " rule of thumb" is that for horizontal tubing runs the temp drop is 100° F/ ft. Another option is to use "cooling towers" to protect the instrument.

Verify the selected elastomer option is appropriate for your operating temperature.

Panel Mounting

Gauges with 2 ½" dials can only be mounted through the rear of the panel. Make the proper panel cutout as shown below. Remove the (4) bezel screws and insert the gauge front through the rear of the panel. Reinstall the bezel screws through the front of the panel and into the gauge bezel. Tighten screws securely in an alternating diagonal pattern.

Electrical Installation and Operating Instructions - Model 522/522C

Panel Mounting (cont.)

Gauges with 4 1/2" dials should be mounted from the front of the panel. Make the cutout as indicated below. Insert the (4) panel studs, finger tight, into the metal inserts located in the rear of the bezel. Insert the gauge through the panel, aligning the panel mounting studs with the holes in the panel. Install the (4) 8-32 nuts onto the studs and tighten securely.

MODEL 522 PANEL CUT-OUT DIMENSIONS

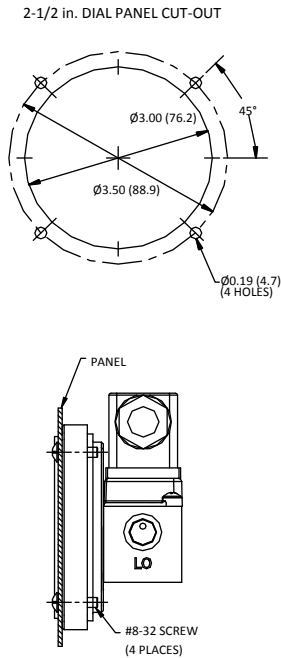

4-1/2 in. DIAL PANEL CUT-OUT

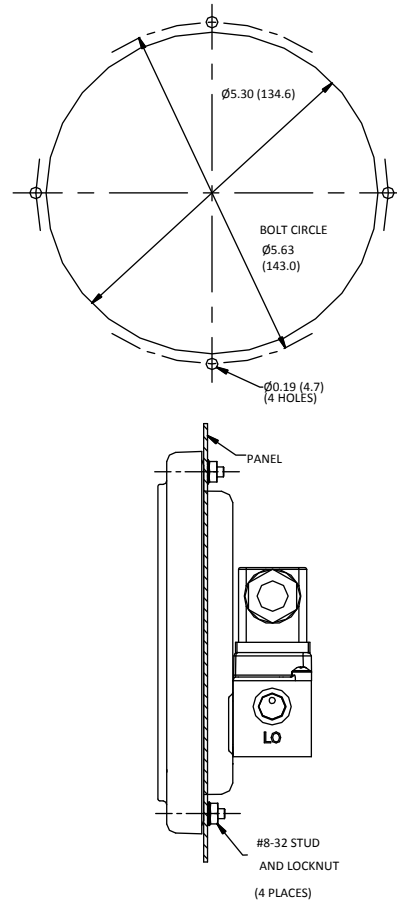

Electrical:



Warning: *Electrical connections should be performed by qualified personnel and meet the representative country's national electrical code.*

Warning: *Perform all switch adjustments with power removed. Use an ohmmeter or equivalent to monitor contact operation.*

Caution: *The switches for this order are pre-set. If they need to be readjusted preference should be given to setting the switch prior to installation.*

Caution: *This product is recommended to be used in Pollution degree 3 type environments, however it may be more suited for Pollution degree 2.*

Caution: *This device does not require power to operate. Connection directly across a mains source will damage the switch.*

Electrical Installation and Operating Instructions - Model 522/522C

General:

Switch Set: The set point of the adjustable switch supplied with your order can be re-adjusted. To increase the switch set-point, loosen the 2 screws and slide the switch away from the Hi port. See Electrical Specifications above for the range of adjustability.

Contact Protection: Provide standard protection techniques for the switch contacts for capacitive and inductive loads. Use current limiting techniques near the switch to protect the contacts due to high inrush (i.e.; in line resistor or inductor) for long cable interfaces. Provide clamping devices at or near inductive loads (i.e.; relay).

Connections: The DIN interface conforms to DIN 43 650A / ISO 4400 and **when mated** provides an IP65 rated protection class. The supplied plug can seal on a jacketed cable with an OD range from 4.5 mm to 7 mm (.177" - .275"). The right angle mating connector is supplied with the gauge upon order. Locking (orientation) can be changed by prying out the insert and rotating the insert to the desired clocking (90° increments).

SPST (LE) wired between terminals 1 & 2.

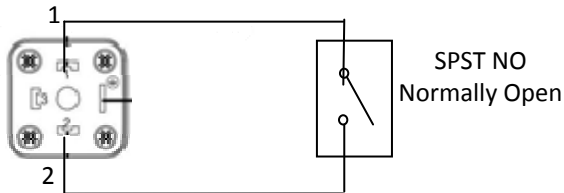

SPDT (LA) 1= Common,
2= Normally Open, 3= Normally Closed



5.0 Dimensions

Model 522 2 1/2" Dial, Optional Switch & Optional Mounting Holes 522-XX-XX-XX (See Bulletin 522/xx for Model Number Configurator)

Model 522C (3 Color 2-1/2" Dial, Switch Option, Mounting Holes present) 522X-XXXX-LX (See Bulletin 522C/XX for Model Number Configurator)

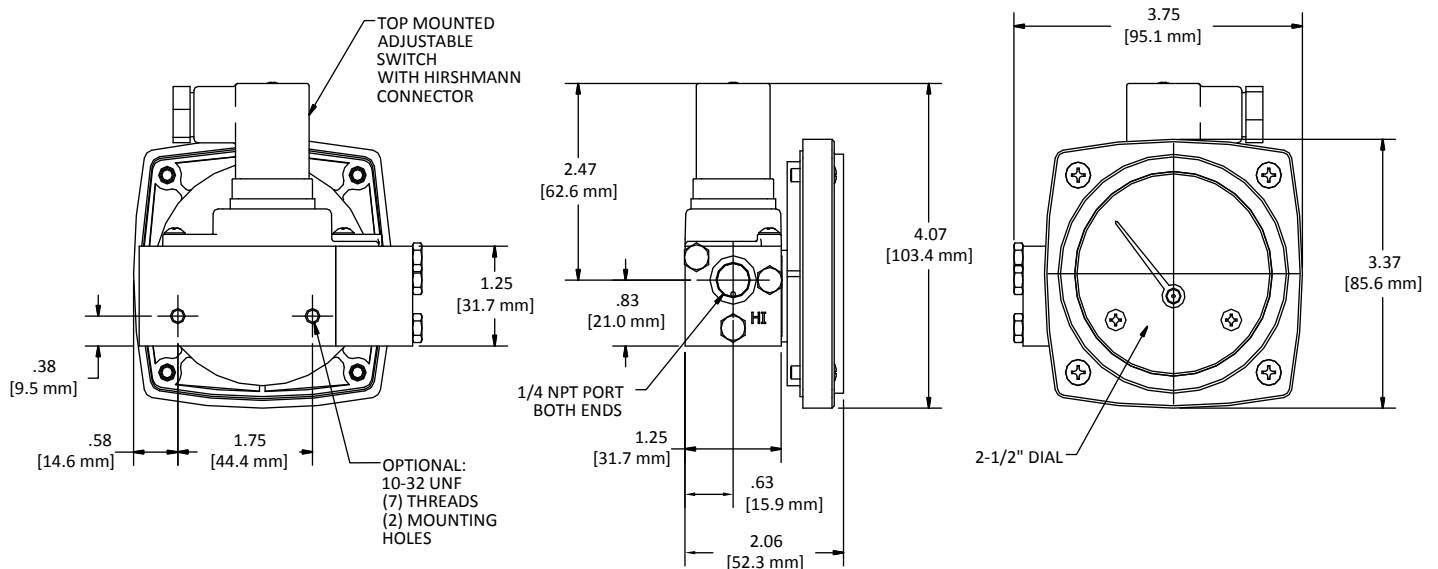

6.0 Troubleshooting

A. Gauge accuracy and set point problems:

- i. Verify your process connections are plumbed properly
- ii. Verify gauge is not in an electromagnetic / magnetic environment. i.e.; close proximity to high current power lines.
- iii. Verify the pointer has fluid movement as pressure increases. Jumpy movement or no movement may indicate a stuck piston
- iv. All others contact the factory for assistance.

B Switch doesn't function

- i. Make sure that the switch load does not exceed the specified wattage rating of the switch. (steady-state and transient). Contact factory for assistance for excessive loads, otherwise proceed to the next step.
- ii. Perform a continuity check of the switch contacts by trying to actuate the switch using an external magnet. An operational switch usually indicates a problem with the gauge. If not operational proceed to the next step.
- iii. Contact the factory for assistance.

7.0 CE Marking Statements:

Low Voltage Directive: This product is CE marked in compliance with the Low Voltage Directive.

ATEX Directive 94/9/EC; Model 522 product has not been evaluated to the ATEX directive.

Pressure Equipment Directive: The Pressure Equipment Directive has been determined to be **non-applicable for CE marking for Group 1 applications below 200 bar or Group 2 applications below 1000 bar.** These products are manufactured in accordance with article 3, paragraph 3 of the directive, "sound engineering practice". They fall below category I for non-hazardous gases, hazardous liquids, & non-hazardous liquids. This product also falls below category I for hazardous gases at or below 200 bar.

For Group 1 applications above 200bar, this product has not been evaluated to meet the essential safety requirements of Annex I of the Pressure Equipment Directive. Use of this product in an EU member state shall be limited to less than 200 bar for Group 1 applications.

ROHS Directive: Compliant with ROHS2 2011/65/EV.

8.0 Misc:

STANDARDS: All Model 522 Series differential pressure gauges either conform to and/or are designed to the requirements of the following standards:

ASME B1.20.1	NACE MR0175
ASME B40.1	NEMA Std. 250
EN-61010-1	UL Std. 50 & 508,

Mating Connector: Connection Instructions

(Note: Delivered connector may appear different from item pictured)



Remove the plug-in connector from the gauge assembly and using a screwdriver pry out the insert from the connector shell.



Insert connection wires through the connector shell as shown.

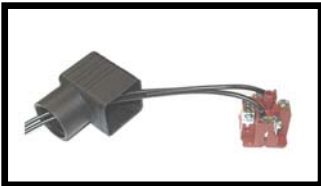

Strip wire lead ends and connect to terminal locations All terminals are marked. A protective conductor terminal connection, while marked, is not required.



Insert terminal connection insert into connector shell. Rotate if necessary to the desired clocking. Tighten Hex compression grommet as necessary to seal on exiting wires.